

IS : 4332 (Part VI) - 1972

(Reaffirmed 2001)

Edition 1.1

(1989-02)

Indian Standard

METHODS OF TEST FOR STABILIZED SOILS

**PART VI FLEXURAL STRENGTH OF SOIL-CEMENT USING
SIMPLE BEAM WITH THIRD-POINT LOADING**

(Incorporating Amendment No. 1)

UDC 624.131.377 : 624.138.23

© BIS 2004

BUREAU OF INDIAN STANDARDS
MANAK BHAVAN, 9 BAHADUR SHAH ZAFAR MARG
NEW DELHI 110002

Price Group 3

*Indian Standard***METHODS OF TEST FOR STABILIZED SOILS****PART VI FLEXURAL STRENGTH OF SOIL-CEMENT USING
SIMPLE BEAM WITH THIRD-POINT LOADING**

Soil Engineering Sectional Committee, BDC 23

Chairman

PROF DINESH MOHAN

Representing

Central Building Research Institute (CSIR), Roorkee

*Members*SHRI D. R. NARAHARI (*Alternate* to
Prof Dinesh Mohan)

PROF ALAM SINGH

University of Jodhpur, Jodhpur

DR A. BANERJEE

Cementation Co Ltd, Bombay

SHRI S. GUPTA (*Alternate*)

SHRI B. B. L. BHATNAGAR

Land Reclamation, Irrigation & Power Research
Institute, Amritsar

SHRI K. N. DADINA

In personal capacity (*P-820, New Alipore, Calcutta 53*)

SHRI A. G. DASTIDAR

Hindustan Construction Co Ltd, Bombay

SHRI R. L. DEWAN

Bihar Institute of Hydraulic & Allied Research,
Khagaul, Patna

DR G. S. DHILLON

Indian Geotechnical Society, New Delhi

DIRECTOR (CENTRAL SOIL

Central Water & Power Commission, New Delhi

M E C H A N I C S RESEARCH
STATION)DEPUTY DIRECTOR (CENTRAL
SOIL MECHANICS RESEARCH
STATION) (*Alternate*)

PROF R. N. DOGRA

Indian Institute of Technology, New Delhi

SHRI S. K. GULATI (*Alternate*)

SHRI B. N. GUPTA

Irrigation Research Institute, Roorkee

JOINT DIRECTOR RESEARCH (FE), Railway Board (Ministry of Railways)
RDSODEPUTY DIRECTOR RESEARCH
(SOIL MECHANICS), RDSO (*Alternate*)

SHRI S. S. JOSHI

Engineer-in-Chief's Branch, Army Headquarters

SHRI S. VARADARAJA (*Alternate*)

SHRI I. P. KAPILA

Central Board of Irrigation & Power, New Delhi

SHRI G. KUECKELMANN

Rodio Foundation Engineering Ltd; and Hazarat & Co,
BombaySHRI A. H. DIVANJI (*Alternate*)(*Continued on page 2*)**BUREAU OF INDIAN STANDARDS**

MANAK BHAVAN, 9 BHADUR SHAH ZAFAR MARG

NEW DELHI 110002

IS : 4332 (Part VI) - 1972

(Continued from page 1)

<i>Members</i>	<i>Representing</i>
SHRI O. P. MALHOTRA	Public Works Department, Government of Punjab
SHRI M. A. MEHTA	Concrete Association of India, Bombay
SHRI T. M. MENON (<i>Alternate</i>)	
SHRI T. K. NATARAJAN	Central Road Research Institute (CSIR), New Delhi
SHRI RAVINDER LAL	National Buildings Organization, New Delhi
SHRI S. H. BALACHANDANI (<i>Alternate</i>)	
RESEARCH OFFICER	Buildings & Roads Research Laboratory, Public Works Department, Government of Punjab
RESEARCH OFFICER	Engineering Research Laboratories, Hyderabad
DR SHAMSHER PRAKASH	University of Roorkee, Roorkee
SHRI S. N. SINHA	Roads Wing (Ministry of Shipping & Transport)
SHRI A. S. BISHNOI (<i>Alternate</i>)	
SUPERINTENDING ENGINEER (PLANNING AND DESIGN CIRCLE)	Concrete & Soil Research Laboratory, Public Works Department, Government of Tamil Nadu
EXECUTIVE ENGINEER (INCHARGE, SOIL MECHANICS & RESEARCH DIVISION) (<i>Alternate</i>)	
SHRI C. G. SWAMINATHAN	Institution of Engineers (India), Calcutta
SHRI H. C. VERMA	All India Instruments Manufacturers & Dealers Association, Bombay
SHRI S. R. TALPADE (<i>Alternate</i>)	
SHRI H. G. VERMA	Public Works Department, Government of Uttar Pradesh
SHRI D. C. CHATURVEDI (<i>Alternate</i>)	
SHRI D. AJITHA SIMHA, Director (Civ Engg)	Director General, ISI (<i>Ex-officio Member</i>)

Secretary

SHRI G. RAMAN

Deputy Director (Civ Engg), ISI

Soil Testing Procedures and Equipment Subcommittee, BDC 23 : 3

Convener

PROF ALAM SINGH University of Jodhpur, Jodhpur

Members

DR R. K. BHANDARI Central Road Research Institute (CSIR), New Delhi
SHRI T. N. BHARGAVA Roads Wing (Ministry of Shipping & Transport)
SHRI A. S. BISHNOI (*Alternate*)
SHRI R. L. DEWAN Bihar Institute of Hydraulic & Allied Research, Khagaul, Patna

(Continued on page 12)

Indian Standard

METHODS OF TEST FOR STABILIZED SOILS

PART VI FLEXURAL STRENGTH OF SOIL-CEMENT USING SIMPLE BEAM WITH THIRD-POINT LOADING

0. FOREWORD

0.1 This Indian Standard (Part VI) was adopted by the Indian Standards Institution on 31 January 1972, after the draft finalized by the Soil Engineering Sectional Committee had been approved by the Civil Engineering Division Council.

0.2 Soil stabilization is the alteration of any property of a soil to improve its engineering performance. There are several methods of stabilization and these may be broadly classified on the basis of treatment given to the soil (for example, dewatering and compaction), process involved (for example, thermal, and electrical), and on additives employed (for example, asphalt and cement). The choice of a particular method depends on the characteristics of the problem on hand. For studying in the laboratory the methods and effects of stabilization, certain standard methods of test for the evaluation of properties of stabilized soils and their analysis are required. The required standards on methods of test for stabilized soils are to be published in parts and this part [IS : 4332 (Part VI)-1972] lays down the procedure for determining the flexural strength of soil-cement by the use of a simple beam with third-point loading.

0.3 In the formulation of this standard due weightage has been given to international co-ordination among the standards and practices prevailing in different countries in addition to relating it to the practices in the field in this country. This has been met by basing the standard on the following publications:

ASTM D1632-63 Making and curing soil-cement compression and flexural test specimens in the laboratory. American Society for Testing and Materials, USA.

ASTM D1635-63 Test for flexural strength of soil-cement using simple beam with third-point loading. American Society for Testing and Materials, USA.

0.4 This edition 1.1 incorporates Amendment No. 1 (February 1989). Side bar indicates modification of the text as the result of incorporation of the amendment.

0.5 In reporting the result of a test or analysis made in accordance with this standard, if the final value, observed or calculated, is to be rounded off, it shall be done in accordance with IS : 2-1960*.

*Rules for rounding off numerical values (*revised*).

IS : 4332 (Part VI) - 1972

1. SCOPE

1.1 This standard covers the procedure for determining the flexural strength of soil-cement by the use of a simple beam with third-point loading.

2. APPARATUS

2.1 For the Preparation of Test Specimen

2.1.1 Moulds — having inside dimensions of $75 \times 75 \times 300$ mm (Fig. 1). The moulds shall be so designed that the specimen may be moulded with its longitudinal axis in a horizontal position. The parts of the moulds shall be tight-fitting and positively held together. The sides of the moulds shall be sufficiently rigid to prevent spreading or warping. The interior faces of the moulds shall be plane surfaces with a permissible variation, in any 75 mm line on a surface, of 0.05 mm for new moulds and 0.075 mm for moulds in use. The distance between opposite sides shall be 75 ± 0.25 mm for new moulds and 75 ± 0.4 for moulds in use. The height of the moulds shall be $75^{+0.25}_{-0.15}$ mm for both new moulds and moulds in use. Four 10-mm spacer bars and top and bottom machined steel plates shall be provided. The plates shall fit the mould with a clearance of 0.15 mm on all sides. The moulds shall be made of metal having a Rockwell hardness between B80 and B85.

2.1.2 Sieves — 50-mm, 20-mm, 4.75-mm, 1.18-mm conforming to the requirements of IS : 460 (Part 1)-1985*.

2.1.3 Balances — A balance or scale of capacity 10 kg, sensitive to 5 g (Class C beam scale of IS : 1433-1965†) and a balance of 1 kg, sensitive to 100 mg (Class B beam scale of IS : 1433-1965†).

2.1.4 Drying Oven — thermostatically controlled, capable of maintaining a temperature of $110 \pm 5^\circ\text{C}$ for drying moisture samples.

2.1.5 Tamping Rod — A square-end cut 12 mm diameter smooth steel rod 500 mm in length.

2.1.6 Moist Room or Cabinet — capable of maintaining a temperature of $27 \pm 2^\circ\text{C}$ and relative humidity of not less than 96 percent for moist curing specimens.

2.2 For Testing Flexural Strength

2.2.1 Testing Machine — The testing machine may be of any type having sufficient capacity (at least 500 kg) and control to provide the rate of loading prescribed in 5.2. The testing machine shall be equipped with a spherically seated head block having a bearing surface of 100 percent of

*Specification for test sieves : Part 1 Wire cloth test sieves (*third revision*).

†Specification for beam scales (*revised*).

the width of the beam but not greatly in excess of the width of the beam. The movable portion of this block shall be held closely in the spherical seat, but the design shall be such that the bearing face may be rotated freely and tilted through small angles in any direction.

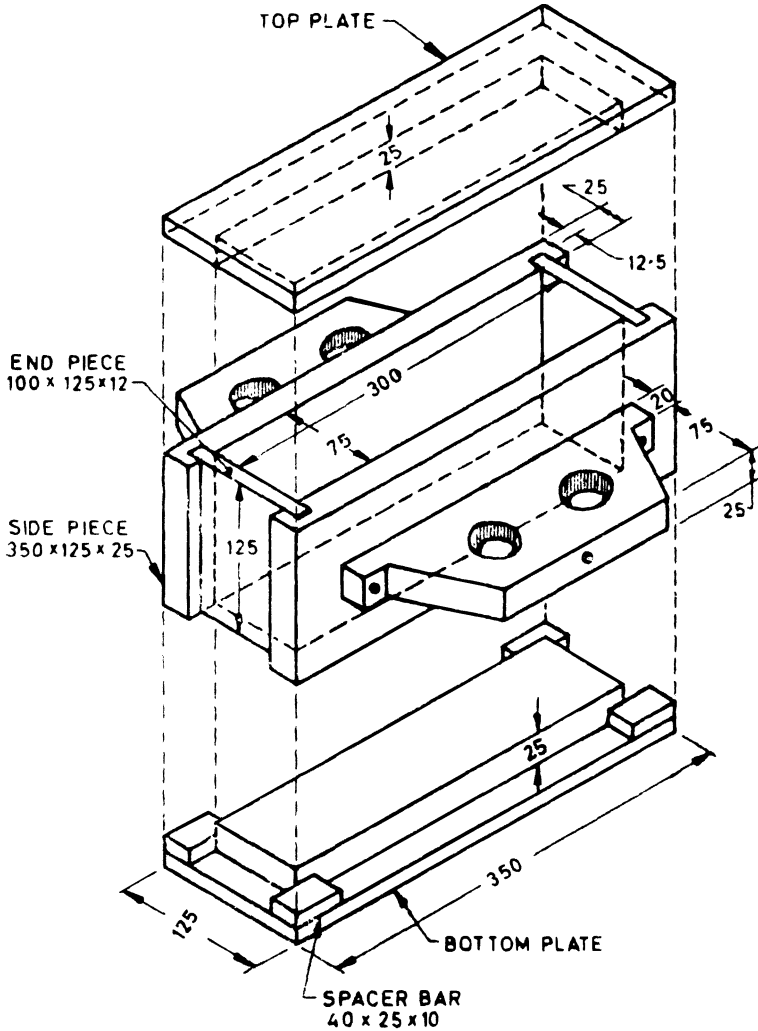

All dimensions in millimetres.

FIG. 1 MOULD FOR SOIL-CEMENT BEAM FOR FLEXURE TEST

IS : 4332 (Part VI) - 1972

2.2.2 The third-point loading method used in making flexure tests of soil-cement shall employ bearing blocks that will ensure that forces applied to the beam will be vertical only and applied without eccentricity. A diagrammatic drawing of an apparatus which satisfies this condition is shown in Fig. 2. The apparatus shall be designed to incorporate the principles given in 2.2.2.1 to 2.2.2.4.

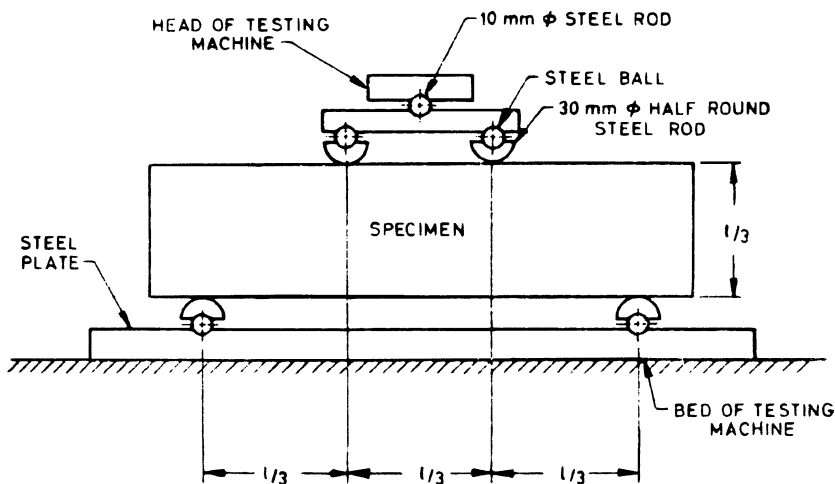

FIG. 2 DIAGRAMMATIC VIEW OF APPARATUS FOR FLEXURE TEST OF SOIL-CEMENT BY THIRD-POINT LOADING METHOD

2.2.2.1 The distance between supports and points of load application shall remain constant for a given apparatus.

2.2.2.2 The direction of the reactions shall be parallel to the direction of the applied load at all times during the test.

2.2.2.3 The load should be applied at a uniform rate and in such a manner as to avoid shock.

2.2.2.4 The directions of loads and reactions may be maintained parallel by use of linkages, rocker bearings and flexure plates. Eccentricity of loading can be avoided by use of spherical bearings.

3. PREPARATION OF MATERIALS

3.1 Materials shall be brought to room temperature.

3.2 Cement — Cement shall be stored in a dry place, in moisture-proof containers, preferably made of metal. The cement shall be thoroughly mixed in order that the sample may be uniform throughout the tests. It shall be passed through a 1.18-mm IS Sieve and all lumps rejected.

3.3 Water — The mixing water shall be free of acids, alkalies, and oils, and in general suitable for drinking.

3.4 Soil

3.4.1 The soil sample, if damp when received from the field, shall be dried until it becomes friable under a trowel. Drying may be in air or by use of drying apparatus such that the temperature of the sample does not exceed 60°C. The aggregations shall be thoroughly broken up in such a manner as to avoid reducing the natural size of individual particles.

3.4.2 An adequate quantity of representative pulverized soil shall be sieved on the 50-mm, 20-mm and 4.75-mm sieves. Any fraction retained on the 50-mm sieve shall be discarded. Fraction passing the 50-mm sieve and retained on the 20-mm sieve shall be removed, and replaced with an equal weight of fraction passing the 20-mm sieve and retained on the 4.75-mm sieve. Soil for replacement shall be obtained from the original sample.

NOTE — It is intended that these methods for making soil-cement specimens for the flexure test be used primarily with soil materials having not more than 35 percent soil retained on the 4.75-mm sieve and not more than 85 percent retained on the 425-micron sieve.

3.4.3 The fraction passing the 20-mm sieve and retained in the 4.75-mm sieve shall be soaked in water for 24 hours, removed and surface dried. The absorption properties of this fraction shall be determined in accordance with IS : 2386 (Part III)-1963*.

3.4.4 A 100-g sample of the soil passing the 4.75-mm sieve shall be taken and dried in the drying oven to constant weight, and the moisture content of the sample determined to permit calculation of the quantity of water that shall be added to the soil-cement mixture to bring it to the proper moisture content for moulding specimens.

3.4.5 A representative sample of sufficient quantity to make three flexure test specimens shall be taken of the soil passing the 4.75-mm sieve and also of the fraction passing the 20-mm sieve and retained on the 4.75-mm sieve prepared as described in **3.4.1**, **3.4.2** and **3.4.3**.

*Methods of test for aggregates for concrete: Part III Specific gravity, density, voids, absorption and bulking.

IS : 4332 (Part VI) - 1972

3.5 Weighing Materials — The designed quantities of soil passing the 4.75-mm sieve and of aggregate passing the 20-mm sieve and retained on the 4.75-mm sieve shall be weighed to the nearest 5 g. The designed quantity of cement shall be weighed to the nearest gram and the designed quantity of water shall be measured to the nearest millilitre.

4. PREPARATION OF TEST SPECIMEN

4.1 Mixing Materials

4.1.1 General — Soil-cement shall be mixed either by hand or in a suitable laboratory mixer in batches of such size as to leave ten percent excess after moulding test specimens. This material shall be protected against loss of moisture, and a representative part of it shall be weighed and dried in the drying oven to constant weight to determine the actual moisture content of the soil cement mixture. When the soil-cement mixture contains aggregate retained on the 4.75-mm sieve, the sample for moisture determination shall weigh at least 500 g and shall be weighed to the nearest gram. If the mixture does not contain aggregate retained on the 4.75-mm sieve, the sample shall weigh at least 100 g and shall be weighed to the nearest 0.1 g.

4.1.2 Hand Mixing — The batch shall be mixed in a clean, damp, metal pan or on top of a steel table, with a blunt brick-layer's trowel, using the following procedures:

- a) Calculated amount of water to give moisture content 2 percent less than the required final moisture content should be added to the soil passing 4.75-mm IS Sieve, thoroughly mixed and kept in a sealed container to avoid moisture loss overnight for uniform distribution of moisture.
- b) The additional water required for bringing the moisture to the required level should be calculated. The calculated weight of the moist soil and cement required for making the specimens should be mixed thoroughly. The remaining quantity of water to make up to the required moisture content of the soil-cement mixture should be added and thoroughly mixed.
- c) The saturated surface-dry coarse fraction of the soil shall be added and the entire batch mixed until the coarse fraction is uniformly distributed throughout the batch.

4.1.3 Machine Mixing — The sequence specified for hand mixing shall be followed. To eliminate segregation, machine-mixed soil-cement shall be deposited in a clean, damp-metal pan and remixed by trowel.

NOTE — The operation of mixing and compacting test specimens shall be continuous and the elapsed time between the addition of water and final compaction shall not exceed 30 minutes.

4.2 Size of Specimens — Flexure test specimens shall be rectangular beams with a length as tested at least 50 mm greater than three times the depth. This procedure provides for beams 75 × 75 × 300 mm, but the same procedure may be used for moulding smaller or larger specimens.

4.3 Moulding Specimens

4.3.1 The test specimens shall be formed with the longitudinal axis horizontal. The mould parts shall be lightly oiled and assembled with sides and ends separated from the base plate by the 10-mm spacer bars, one placed at each corner of the mould.

4.3.2 Divide into three equal batches a predetermined weight of uniformly mixed soil-cement to make a beam of the designed density. Place one batch of the material in the mould and level by hand. When the soil-cement contains aggregate retained on the 4.75-mm sieve, carefully spade the mix around the sides of the mould with a thin spatula. Compact the soil-cement initially from the bottom up by steadily and firmly forcing (with little impact) a square-end cut 12 mm diameter smooth steel rod repeatedly through the mixture from the top down to the point of refusal. Approximately 90 roddings distributed uniformly over the cross-section of the mould are required; take care so as not to leave holes in clayey soil-cement mixtures. Level this layer of compacted soil-cement by hand and place and compact layers two and three in an identical manner. The specimen at this time shall be approximately 95 mm high.

4.3.3 Place the top plate of the mould in position and remove the spacer bars. Obtain final compaction with a static load applied by the compression machine or compression frame until the height of 75 mm is reached.

4.3.4 Immediately after compaction, carefully dismantle the mould and remove the specimen onto a smooth, rigid wood or sheet metal pallet.

NOTE — A suggested method for removing the specimen from the mould is to remove first the top and then the sides and end plates of the mould. The specimen is then resting on the bottom plate of the mould. The flat face of a carrying pallet is then placed against one side of the specimen and then the bottom mould plate, the specimen, and the pallet are rotated 90° so that the specimen rests on its side on the pallet. The bottom mould plate is then carefully removed.

4.4 Curing the Specimens — Cure the specimens on pallets in the moist room and protect from free water for the specified moist curing period. Generally the specimen will be tested in the moist condition directly after removal from the moist room.

NOTE — Other conditioning procedures, such as soaking in water, air drying or oven drying, alternate wetting and drying, or alternate freezing and thawing, may be specified after an initial moist curing period. Curing and conditioning procedures shall be given in detail in the report.

IS : 4332 (Part VI) - 1972

4.4.1 Flexural test of moist cured specimens shall be made as soon as practicable after removing from the moist room, and during the period between removal from the moist room and testing, the specimens shall be kept moist by a wet burlap or blanket covering.

4.5 Report — The report on the preparation of specimens shall include the following:

- a) Gradation of soil as received and as used in making specimens,
- b) Specimen identification number,
- c) Designed moisture content,
- d) Designed oven-dry density,
- e) Designed cement content,
- f) Actual moisture content,
- g) Actual oven-dry density,
- h) Actual cement content, and
- j) Details of curing and conditioning periods.

5. PROCEDURE FOR FLEXURAL TEST

5.1 Turn the specimen on its side with respect to its moulded position (with the original top and bottom surfaces as moulded perpendicular to the testing machine bed) and centre it on the lower half-round steel supports, which shall have been spaced apart a distance of three times the depth of the beam. Place the load applying block assembly in contact with the upper surface of the beam at the third points between the supports. Carefully align the centre of the beam with the centre of thrust of the spherically seated head block of the machine. As this block is brought to bear on the beam-loading assembly, rotate its movable portion gently by hand so that uniform seating is obtained.

5.2 Apply the load continuously and without shock. A screw power testing machine, with the moving head operating at approximately 1.2 mm/min when the machine is running idle may be used. With hydraulic machines adjust the loading to such a constant rate that the extreme fibre stress is within the limits of $7 \pm 0.4 \text{ kg/cm}^2/\text{min}$. Record the total load at failure of the specimen to the nearest 5 kg.

6. MEASUREMENTS OF SPECIMENS AFTER TEST

6.1 Make measurements to the nearest 0.2 mm to determine the average width and depth of the specimens at the section of failure.

7. CALCULATIONS

7.1 If the fracture occurs within the middle third of the span length, calculate the modulus of rupture as follows:

$$R = \frac{Pl}{bd^2} \text{ (weight of beam neglected)}$$

$$R = \frac{l}{bd^2} \left(P + \frac{3}{4} W \right) \text{ (weight of beam taken into account)}$$

where

- R = modulus of rupture in kg/cm²,
- P = maximum applied load in kg,
- l = span length in cm,
- b = average width of specimen in cm,
- d = average depth of specimen in cm, and
- W = weight of the specimen in kg.

7.2 If the fracture occurs outside the middle third of the span length by not more than 5 percent of the span length, calculate the modulus of rupture as follows:

$$R = \frac{3Pa}{bd^2}$$

where

- a = distance between line of fracture and the nearest support, measured along the centre line of the bottom surface of the beam (as tested).

8. REPORT

8.1 The report shall include the following:

- a) Specimen preparation details in accordance with **4.5**;
- b) Specimen identification number;
- c) Average width and depth at section of failure to the nearest 0.2 mm;
- d) Maximum load, to the nearest 5 kg;
- e) Modulus of rupture calculated to the nearest 0.5 kg/cm²;
- f) Defects, if any, in specimen;
- g) Age of specimen; and
- h) Moisture content at time of test.

IS : 4332 (Part VI) - 1972

(Continued from page 2)

<i>Members</i>	<i>Representing</i>
DIRECTOR (CENTRAL SOIL MECHANICS RESEARCH STATION)	Central Water & Power Commission, New Delhi
DEPUTY DIRECTOR (CENTRAL SOIL MECHANICS RESEARCH STATION) (<i>Alternate</i>)	
SHRI H. K. GUHA	Geologists Syndicate Private Ltd, Calcutta
SHRI N. N. BHATTACHARYYA (<i>Alternate</i>)	
SHRI S. K. GULHATI	Indian Institute of Technology, New Delhi
SHRI S. S. JOSHI	Engineer-in-Chief's Branch, Army Headquarters
SHRI O. P. MALHOTRA	Buildings & Road Research Laboratory, Public Works Department, Government of Punjab
DR I. S. UPPAL (<i>Alternate</i>)	
SHRI D. R. NARAHARI	Central Building Research Institute (CSIR), Roorkee
SHRI G. S. JAIN (<i>Alternate</i>)	
DR V. V. S. RAO	United Technical Consultants Pvt Ltd, New Delhi
SHRI K. K. GUPTA (<i>Alternate</i>)	
REPRESENTATIVE	Public Works Department, Government of Uttar Pradesh
SHRI H. C. VERMA	Associated Instrument Manufacturers (India) Pvt Ltd, New Delhi
SHRI M. N. BALIGA (<i>Alternate</i>)	

