

IS : 4332 (Part II) - 1967

(Reaffirmed 2001)

Edition 1.1

(1983-08)

Indian Standard

METHODS OF TEST FOR STABILIZED SOILS

**PART II DETERMINATION OF MOISTURE
CONTENT OF STABILIZED SOIL
MIXTURES**

(Incorporating Amendment No. 1)

UDC 624.131.431.3

© BIS 2004

BUREAU OF INDIAN STANDARDS
MANAK BHAVAN, 9 BAHADUR SHAH ZAFAR MARG
NEW DELHI 110002

Price Group 5

Indian Standard

METHODS OF TEST FOR STABILIZED SOILS

**PART II DETERMINATION OF MOISTURE
CONTENT OF STABILIZED SOIL
MIXTURES**

Soil Engineering Sectional Committee, BDC 23

Chairman

PROF S. R. MEHRA

Representing

Central Road Research Institute (CSIR), New Delhi

Members

SHRI B. B. L. BHATNAGAR

Land Reclamation, Irrigation and Power Research Institute, Amritsar

SHRI K. C. CHANDIOK
SHRI VED PRAKASH (*Alternate*)

All India Instruments Manufacturers & Dealers Association, Bombay

SHRI K. N. DADINA

In personal capacity (*P 820, New Alipore, Calcutta 53*)

SHRI A. G. DASTIDAR

Cementation Co Ltd, Bombay

SHRI R. L. DEWAN

Bihar Institute of Hydraulic and Allied Research, Khagaul, Patna

PROF DINESH MOHAN

Central Building Research Institute (CSIR), Roorkee

SHRI D. R. NARAHARI (*Alternate*)
DIRECTOR (CENTRAL SOIL
MECHANICS RESEARCH STATION)

Central Water & Power Commission, New Delhi

DIRECTOR (DAMS II) (*Alternate*)

SHRI R. N. DOGRA

Indian Institute of Technology, New Delhi

EXECUTIVE ENGINEER (SOIL
MECHANICS AND RESEARCH
DIVISION)

Public Works Department, Madras

SHRI B. N. GUPTA

Irrigation Research Institute, Roorkee

SHRI S. N. GUPTA

Central Board of Irrigation & Power, New Delhi

DR JAGDISH NARAIN

University of Roorkee, Roorkee

JOINT DIRECTOR RESEARCH
(CIVIL), RDSO

Railway Board (Ministry of Railways)

DEPUTY DIRECTOR RESEARCH
(SOIL MECHANICS), RDSO (*Alternate*)

SHRI S. S. JOSHI

Engineer-in-Chief's Branch, Army Headquarters

SHRI S. VARADARAJA (*Alternate*)

SHRI O. P. MALHOTRA

Public Works Department, Government of Punjab

SHRI K. K. NAMBIAR

Concrete Association of India, Bombay

SHRI T. M. MENON (*Alternate*)

(Continued on page 2)

BUREAU OF INDIAN STANDARDS

MANAK BHAVAN, 9 BAHADUR SHAH ZAFAR MARG

NEW DELHI 110002

IS : 4332 (Part II) - 1967

(Continued from page 1)

<i>Members</i>	<i>Representing</i>
SHRI C. B. PATEL	M. N. Dastur & Co (Private) Ltd, Calcutta
SHRI PRITAM SINGH	Indian National Society of Soil Mechanics & Foundation Engineering, New Delhi
REPRESENTATIVE	Public Works (Special Roads) Directorate, Government of West Bengal
REPRESENTATIVE	Engineering Research Department, Hyderabad
RESEARCH OFFICER	B & R Research Laboratory, Chandigarh
SHRI C. G. SWAMINATHAN	Institution of Engineers (India), Calcutta
SHRI D. N. TEKCHANDANI	National Buildings Organization, New Delhi
SHRI B. S. BHATTI (<i>Alternate</i>)	Roads Wing (Ministry of Transport & Shipping)
SHRI J. M. TREHAN	Central Road Research Institute (CSIR), New Delhi
SHRI T. N. BHARGAVA (<i>Alternate</i>)	Public Works Department, Government of Uttar Pradesh
DR H. L. UPPAL	Director General, ISI (<i>Ex-officio Member</i>)
SHRI H. G. VERMA	
SHRI D. C. CHATURVEDI (<i>Alternate</i>)	
SHRI R. NAGARAJAN,	
Director (Civ Engg)	

Secretary

SHRI G. RAMAN

Deputy Director (Civ Engg), ISI

Soil Testing Procedures and Equipment Subcommittee, BDC 23 : 3

Convener

DR H. L. UPPAL	Central Road Research Institute (CSIR), New Delhi
----------------	---

Members

PROF ALAM SINGH	University of Jodhpur, Jodhpur
SHRI R. L. DEWAN	Bihar Institute of Hydraulic and Allied Research, Khagaul, Patna
DIRECTOR (CENTRAL SOIL MECHANICS RESEARCH STATION)	Central Water & Power Commission, New Delhi
DIRECTOR (DAMS II) (<i>Alternate</i>)	
SHRI H. K. GUHA	Geologist's Syndicate Private Limited, Calcutta
SHRI N. N. BHATTACHARYYA (<i>Alternate</i>)	
SHRI MAHABIR PRASAD	Public Works Department, Government of Uttar Pradesh
SHRI O. P. MALHOTRA	B & R Research Laboratory, Public Works Department, Government of Punjab
DR I. S. UPPAL (<i>Alternate</i>)	
SHRI D. R. NARAHARI	Central Building Research Institute (CSIR), Roorkee
SHRI G. S. JAIN (<i>Alternate</i>)	
SHRI H. C. VERMA	Associated Instrument Manufacturers (India) Private Limited, New Delhi

Indian Standard

METHODS OF TEST FOR STABILIZED SOILS

PART II DETERMINATION OF MOISTURE CONTENT OF STABILIZED SOIL MIXTURES

0. FOREWORD

0.1 This Indian Standard (Part II) was adopted by the Indian Standards Institution on 20 October 1967, after the draft finalized by the Soil Engineering Sectional Committee had been approved by the Civil Engineering Division Council.

0.2 Soil stabilization is the alteration of any property of a soil to improve its engineering performance. There are several methods of stabilization and these may be broadly on the basis of treatment given to the soil (for example, dewatering and compaction), process involved (for example, thermal and electrical) and on additives employed (for example, asphalt and cement). The choice of a particular method depends on the characteristics of the problem on hand. For studying in the laboratory the methods and effects of stabilization, certain standard methods of test for the evaluation of properties of stabilized soils and their analysis are required. This standard [IS : 4332 (Part II)-1967] on methods of test for stabilized soils is being published in parts and this part [IS : 4332 (Part II)-1967] lays down the methods for the determination of moisture content of stabilized soil mixtures.

0.3 In the formulation of this standard due weightage has been given to international co-ordination among the standards and practices prevailing in different countries in addition to relating it to the practices in the field in this country. This has been met by basing the standard on B.S. 1924 : 1957 'Methods of test for stabilized soils' issued by the British Standards Institution.

0.4 This edition 1.1 incorporates Amendment No. 1 (August 1983). Side bar indicates modification of the text as the result of incorporation of the amendment.

0.5 In reporting the result of a test or analysis made in accordance with this standard, if the final value, observed or calculated, is to be rounded off, it shall be done in accordance with IS : 2-1960*.

1. SCOPE

1.1 This standard (Part II) lays down the method for the determination of moisture content of stabilized soil mixtures with non-volatile stabilizers (Section 1) and with volatile stabilizers (Section 2).

*Rules for rounding off numerical values (*revised*).

SECTION I STABILIZED SOIL MIXTURES WITH NON-VOLATILE STABILIZERS (OVEN DRYING METHOD)

2. APPARATUS

2.1 Drying Oven — thermostatically controlled and capable of maintaining a temperature of 105° to 110°C.

2.2 For stabilized soil mixtures 90 percent of which pass a 2-mm IS Sieve, the following apparatus are required.

2.2.1 Glass Weighing Bottle — fitted with a ground glass stopper or cap, or a suitable air-tight non-corrodible metal container (a convenient size is 5 cm diameter and 2.5 cm high).

2.2.2 Balance — readable and accurate to 0.01 g.

2.2.3 Desiccator — with any desiccating agent other than sulphuric acid.

2.3 For stabilized soil mixtures 90 percent of which pass a 20-mm IS Sieve, the following apparatus are required.

2.3.1 Container — air-tight non-corrodible of about 500 g capacity.

2.3.2 Balance — readable and accurate to 0.1 g.

2.3.3 Scoop — A convenient size is one about 20 cm long and 10 cm wide.

2.4 For stabilized soil mixtures 90 percent of which pass a 40-mm IS Sieve, the following apparatus are required.

2.4.1 Container — air-tight non-corrodible of about 3 kg capacity.

2.4.2 Balance — readable and accurate to 1 g.

2.4.3 Scoop — A convenient size is one about 20 cm long and 10 cm wide.

3. SOIL SAMPLE

3.1 For determination of the moisture content of a stabilized soil mixture, the size of the sample taken shall be such that it is representative of the mass. This is influenced by the gradation and the maximum size of the particles, and on the accuracy of weighing. The following quantities are recommended for general laboratory use:

<i>Grading of Soil</i>	<i>Minimum Quantity of Sample, Weight in g</i>
For stabilized soil mixture 90 percent of which passes a 2-mm IS Sieve	30
For stabilized soil mixture 90 percent of which passes a 20-mm IS Sieve	300

*Grading of Soil**Minimum Quantity of
Sample, Weight in g*

For stabilized soil mixture 90 percent of
which passes a 40-mm IS Sieve

3 000

NOTE 1 — For sizes of sieves, see IS : 460 (Part 1)-1978*.

NOTE 2 — Drier the soil higher shall be the weight of the soil taken.

4. PROCEDURE

4.1 The container with the lid shall be cleaned, dried and weighed (W_1). The sample of stabilized soil mixture of which the moisture content is required shall be crumbled and placed loosely in the container and the container weighed with the lid (W_2). The lid shall be removed and the container with its lid shall then be kept in the oven, the temperature of which is maintained between 105°C and 110°C. The sample shall be dried in the oven to constant weight. The lid shall not be replaced while the sample is in the oven. After drying the container and contents shall be removed from the oven, the lid replaced and the whole allowed to cool. For stabilized soil mixtures of the type indicated in **2.2** the oven dried sample shall be cooled in the desiccator. The final constant weight (W_3) of the container with the lid and the oven dried sample shall be determined. All the weights in this test shall be determined to an accuracy 0.04 percent of the weight of the sample taken for the test.

NOTE 1 — For complete drying, stabilized soil mixtures of sandy soils take about four hours and those of clays take about 14 to 16 hours. The drying time will also depend on the amount of material in the oven.

NOTE 2 — Certain soils contain gypsum which, on heating, loses its water of crystallization. In such cases, the moisture content determined by this method may not be the moisture content desired. If it is suspected that gypsum is present in the soil used, the sample used for moisture content determination shall be dried at not more than 80°C and possibly for a longer time.

NOTE 3 — *Soils Stabilized With Cement or Lime* — The measured moisture contents of cement or lime stabilized soil samples are low because the water of hydration of the cement or of the lime-clay reaction cannot be removed by normal drying processes. The error in the result depends on a number of factors, the chief of which are the age of the sample and the rate at which water is removed once the sample is placed in the oven. It may be as high as 20 percent of the stabilizer content for samples that are older than 28 days or in cases where because of the large size of sample taken, or to overloading of the oven, drying is very slow.

5. CALCULATIONS

5.1 In the case of soil stabilized with a solid stabilizer the moisture content (w) shall be calculated as a percentage of the dry soil plus stabilizer weight from the formula:

$$w = \frac{W_2 - W_3}{W_3 - W_1} \times 100 \text{ percent}$$

*Specification for test sieves: Part I Wire cloth test sieves (*second revision*).

IS : 4332 (Part II) - 1967

where

W_2 = weight of container with lid with wet soil,

W_3 = weight of container with lid with dry soil, and

W_1 = weight of empty container with lid.

5.2 In the case of soil stabilized with a fluid stabilizer, the moisture content (w) shall be calculated as a percentage of the dry soil weight, from the formula:

$$w = \frac{W_2 - W_3}{W_3 - W_1} (100 + s) \text{ percent}$$

where

s = the non-aqueous fluid stabilizer content of the stabilized soil, expressed as a percentage by weight of dry soil.

6. REPORTING OF RESULTS

6.1 The results of the test shall be tabulated suitably. A recommended proforma is given in Appendix A.

6.2 To moisture content w or W shall be reported to two significant figures.

SECTION 2 STABILIZED SOIL MIXTURES WITH VOLATILE STABILIZERS (DISTILLATION METHOD)

7. SCOPE

7.1 This method covers the determination of the moisture content of stabilized soil as a percentage of the weight of the dry soil or weight of dry soil plus stabilizer. It is necessary to use this method when the stabilizer contains a significant proportion of volatile matter, for example, in the case of certain bituminous materials. The method may also be used with other stabilizing agents.

8. APPARATUS

8.1 For stabilized soil mixtures 90 percent of which passes a 2-mm IS Sieve, the following apparatus and a carrier liquid (**8.1.4**) are required.

8.1.1 *Distillation Apparatus* — A distillation apparatus as shown in Fig. 1 comprising:

- a) a round bottom flask of 500-ml capacity, the top of which shall be ground to form a suitable socket;

- b) a water cooled glass condenser with shape, and dimensions shown in Fig. 1; and
- c) a 25-ml glass receiver with ground glass joints of the shape, dimensions and tolerances given in Fig. 1 and below:

Volume equivalent to smallest sub-division 0.2 ml

Tolerance on capacity 0.1 ml

The graduated portion of the receiver shall be cylindrical throughout its length. The graduation marks shall be fine, cleanly etched permanent lines of uniform thickness, lying in planes at right angles to the axis of the tube. They shall be confined to the cylindrical portion of the tube and there shall be no evident irregularity in their spacing. The graduation marks of every millilitre shall be carried completely round the tube and other marks shall be carried approximately two-thirds of the way round the tube. The graduations shall be numbered from bottom to top.

8.1.2 Balance — readable and accurate to 0.1 g.

8.1.3 Wire — a length of 0.71 mm metal wire approximately 60 cm long.

8.1.4 Carrier Liquid — either toluole (nitration grade) or petroleum spirit.

8.2 For stabilized soil mixtures 90 percent of which passes 20-mm IS Sieve, the following apparatus and carrier liquid (**8.2.5**) are required.

8.2.1 Distillation Apparatus — A distillation apparatus as shown in Fig. 2 to 4 comprising:

- a) a metal still approximately 90 mm internal diameter and 150 mm long, having a flange at the top, to which the head can be tightly attached by means of a clamp. The head is also of metal and a graphited asbestos gasket moistened with the water extraction spirit is provided for insertion between the flange and the head (*see* Fig. 3). The still head shall be joined by means of a flanged joint or, alternatively, by means of a cork fitting into an outlet tube of about 2.5 cm diameter (*see* Fig. 2 and 4);
- b) a water cooled glass condenser with shape and dimensions shown in Fig. 2; and
- c) a 25-ml glass receiver with ground glass joints with a stop cock and of the shape, dimensions and tolerances given in Fig. 2. The other requirements given in **8.1.1(c)** shall also be satisfied.

8.2.2 Measuring Cylinder — of 100 ml capacity conforming to IS : 878-1975*.

*Specification for graduated measuring cylinders (*first revision*).

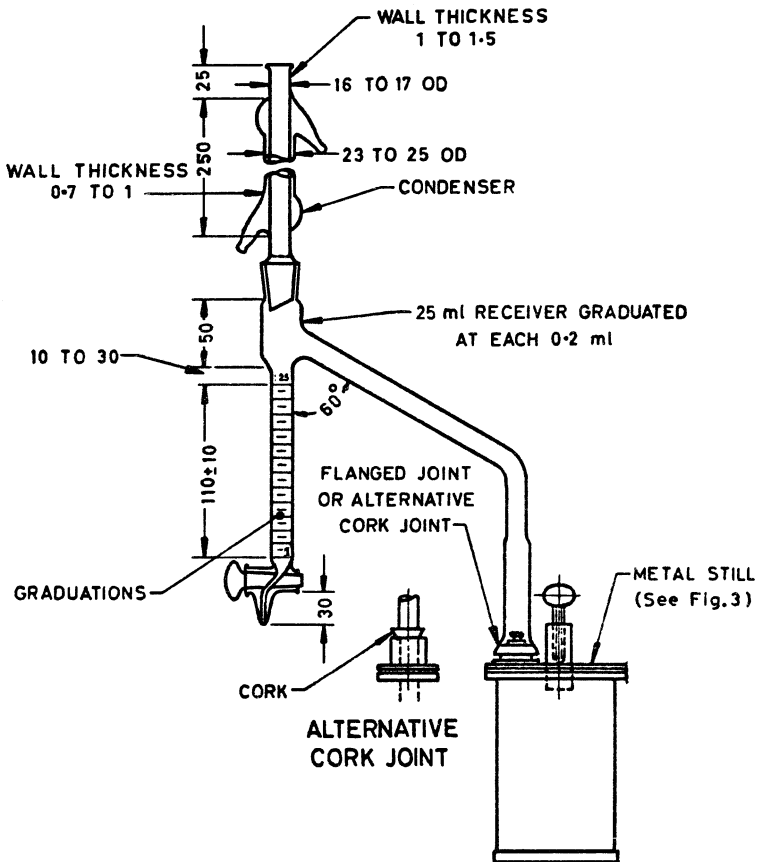

NOTE — This design has been found satisfactory, but alternative designs may be employed, provided that the essential requirements are fulfilled.

All dimensions in millimetres.

FIG. 2 APPARATUS FOR THE DETERMINATION OF MOISTURE CONTENT BY DISTILLATION (FOR STABILIZED SOIL MIXTURE 90 PERCENT OF WHICH PASSES A 20-mm IS SIEVE)

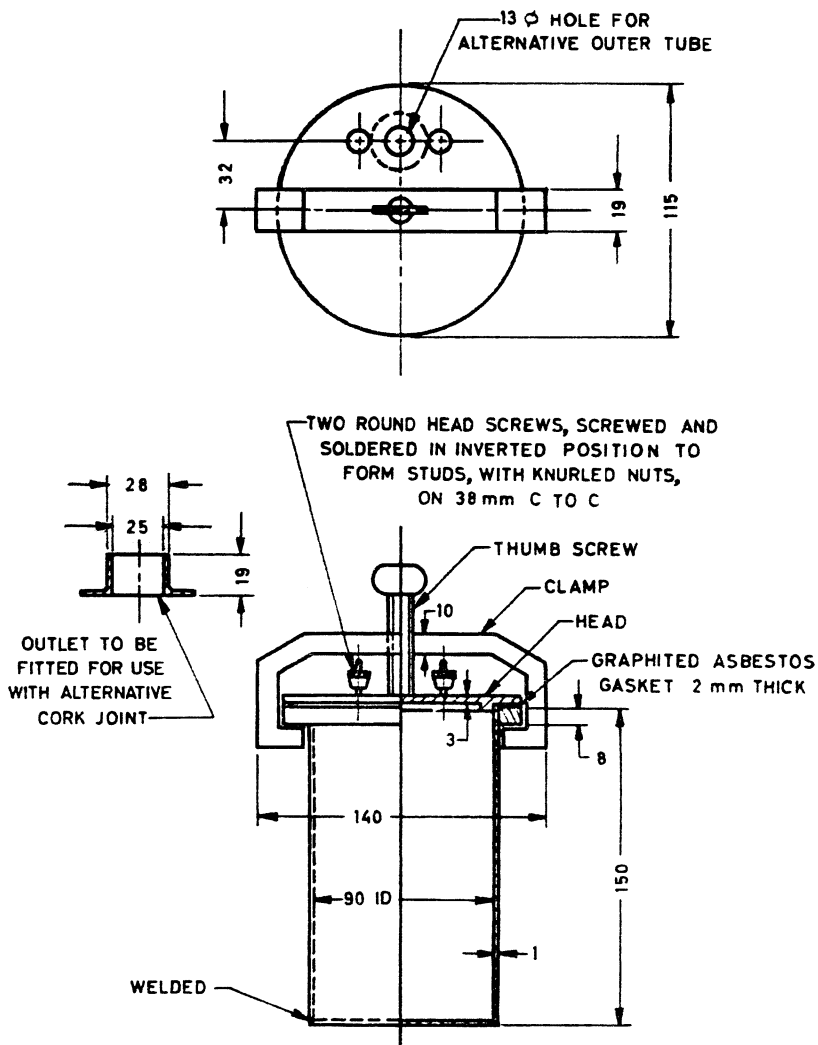

NOTE — This design has been found satisfactory, but alternative designs may be employed, provided that the essential requirements are fulfilled.

All dimensions in millimetres.

FIG. 3 METAL STILL FOR THE DETERMINATION OF MOISTURE CONTENT BY DISTILLATION (FOR STABILIZED SOIL MIXTURE 90 PERCENT OF WHICH PASSES A 20-mm IS SIEVE)

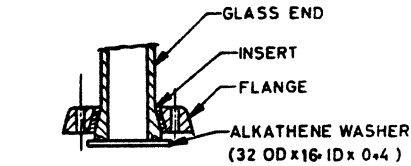

FLANGED JOINT ASSEMBLY

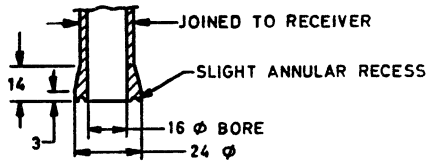

TAPERED GLASS RECEIVER

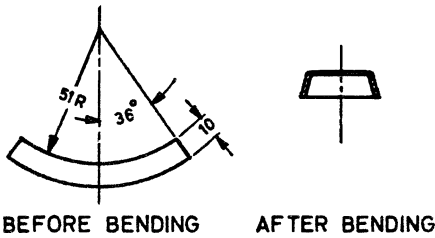

2 mm GRAPHITED ASBESTOS INSERT

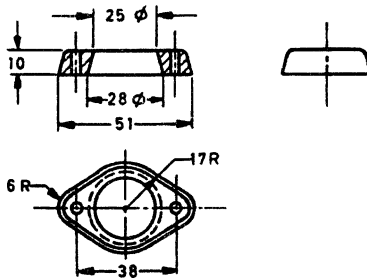

PLASTIC OR METAL FLANGE

NOTE — This design has been found satisfactory, but alternative designs may be employed, provided that the essential requirements are fulfilled.

All dimensions in millimetres.

FIG. 4 ASSEMBLY AND DETAILS OF FLANGED JOINT BETWEEN RECEIVER AND METAL STILL

IS : 4332 (Part II) - 1967

8.3 For stabilized soil mixtures 90 percent of which passes a 40-mm IS Sieve, the following apparatus and a carrier liquid (**8.3.5**) are required.

8.3.1 Distillation Apparatus — A distillation apparatus as shown in Fig. 5 and 6 comprising:

- a) a metal still approximately 18 cm internal diameter and 30 cm long, having a flanged face at the top to which the head can be tightly attached by means of nuts. The head is also of metal and graphited asbestos gasket moistened with the water extraction spirit is provided for insertion between the flange and the head (*see* Fig. 6). The still head and receiver shall be joined by means of a flanged joint or, alternatively, by means of a cork fitting into an outlet tube of about 4.5 cm diameter (*see* Fig. 4 and 5);
- b) a water cooled glass condenser with shape and dimensions shown in Fig. 5; and
- c) a 100-ml glass receiver with ground glass joints of the shape, dimensions and tolerances given in Fig. 5 and below:

Volume equivalent to smallest sub-division	1 ml
Tolerance on capacity	1.0 ml

The graduation marks shall be confined to the front of the tube and shall be varied in length as shown in Fig. 5.

8.3.2 Measuring Cylinder — of 500-ml capacity conforming to IS : 878-1975*.

8.3.3 Balance — readable and accurate to 5 g.

8.3.4 Wire — a length of 0.71 mm metal wire approximately 60 cm long.

8.3.5 Carrier Liquid — either toluole (nitration grade) or petroleum spirit.

9. SOIL SAMPLE

9.1 For determination of the moisture content of a stabilized soil mixture the size of the sample taken shall be such that it is representative of the mass. This is influenced by the gradation and the maximum size of the particles, on the accuracy of weighing and upon their moisture content. The following quantities are recommended for general use:

<i>Grading</i>	<i>Minimum Quantity of Sample, Weight in g</i>
For stabilized soil mixture 90 percent of which passes a 2-mm IS Sieve	200
For stabilized soil mixture 90 percent of which passes a 20-mm IS Sieve	500
For stabilized soil mixture 90 percent of which passes a 40-mm IS Sieve	3 000

*Specification for graduated measuring cylinders (*first revision*).

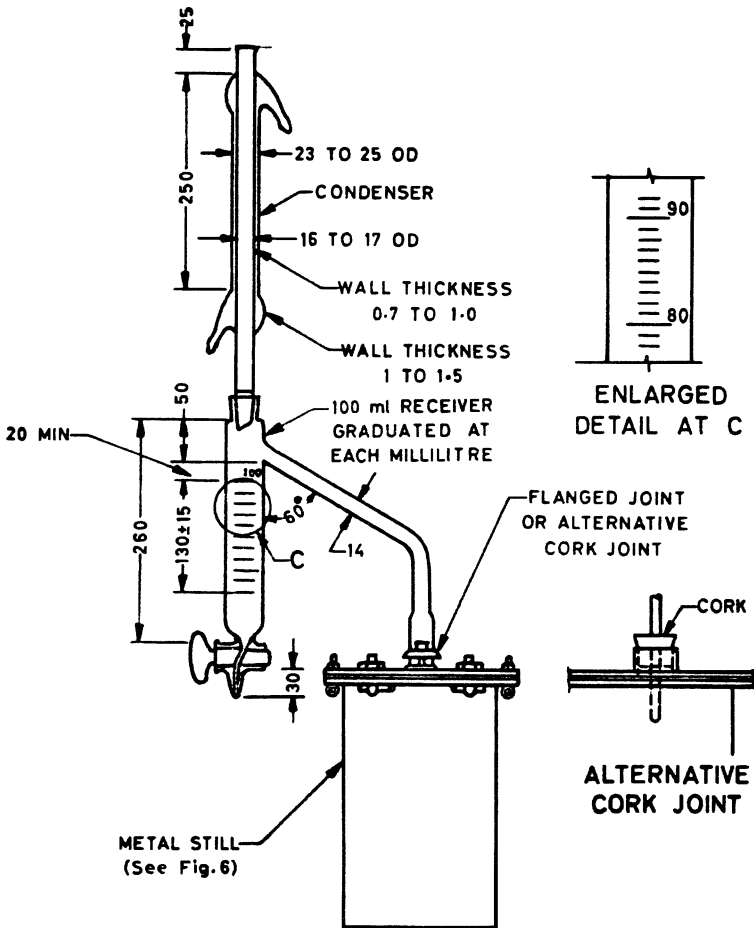

NOTE — This design has been found satisfactory, but alternative designs may be employed, provided that the essential requirements are fulfilled.

All dimensions in millimetres.

FIG. 5 APPARATUS FOR THE DETERMINATION OF MOISTURE CONTENT BY DISTILLATION (FOR STABILIZED SOIL MIXTURE 90 PERCENT OF WHICH PASSES A 40-mm IS SIEVE)

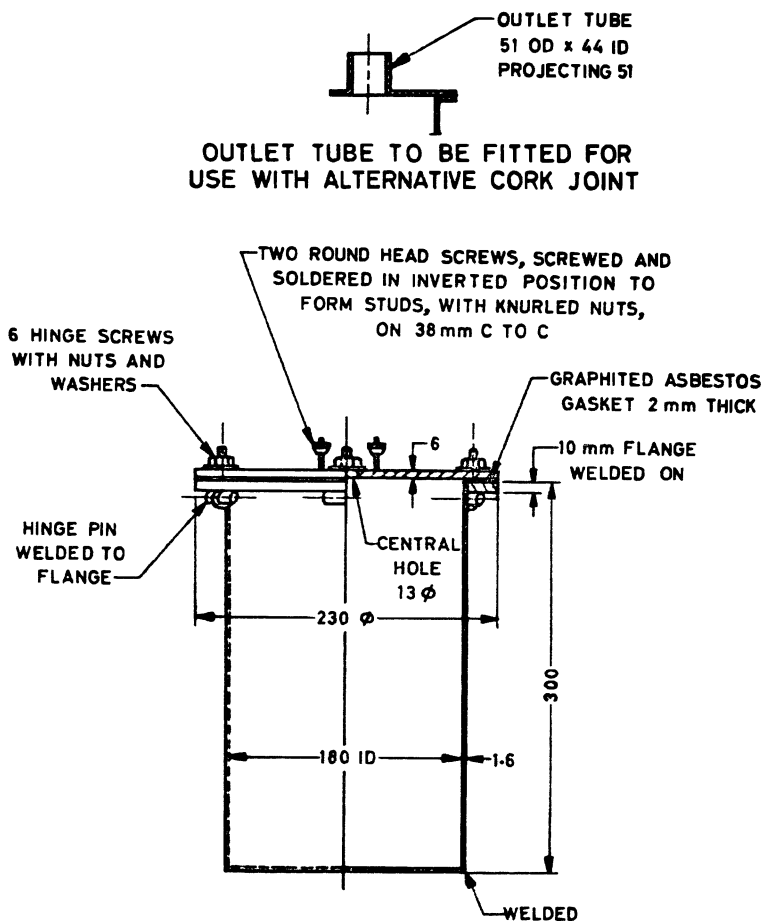

NOTE — This design has been found satisfactory, but alternative designs may be employed, provided that the essential requirements are fulfilled.

All dimensions in millimetres.

FIG. 6 METAL STILL FOR THE DETERMINATION OF MOISTURE CONTENT BY DISTILLATION (FOR STABILIZED SOIL MIXTURE 90 PERCENT OF WHICH PASSES A 40-mm IS SIEVE)

9.2 The quantity of stabilized soil mixture should preferably be such that it yields approximately 15 ml of water in the case of the first two grades of stabilized soil mixture and approximately 60 ml in the case of the third grade (*see 9.1*).

10. PROCEDURE

10.1 The sample of stabilized soil obtained in **9** shall be weighed (weight W_1) to the balance accuracies specified for each grading of stabilized soil mixture (*see 8.1.2, 8.2.3 and 8.3.3*). With soils stabilized with a fluid stabilizer, unless the fluid stabilizer contents is known, it shall be determined by a suitable method.

10.2 Carrier liquid shall be placed in the flask or still with the sample, in the proportion of 1 ml liquid to 1 g of the sample. The apparatus shall then be assembled by connecting the flask or still and the condenser to the receiver, care being taken that the lower end of the condenser is remote from the delivery tube of the receiver.

10.2.1 If there is any reason to suppose that the sample will yield less than 5 ml of water after distillation, 5 ml of distilled water shall be measured out with a pipette into the graduated receiver before the commencement of the test.

10.3 Cold water shall be circulated through the water jacket of the condenser, and heat shall be applied to the flask or still and adjusted so as to avoid any intense local heating, while providing a steady reflux action, so that the condensate falls from the end of the condenser at a rate of two to five drops per second. If more than 25 ml or 100 ml collects in the receivers as shown in Fig. 2 and 5 respectively it shall be drained off into the measuring cylinder, leaving about 2 ml and 10 ml respectively in the receiver on each occasion.

10.4 Distillation shall be maintained until no condensed water accumulates in any part of the apparatus except at the bottom of the receiver. Any ring of condensed water at the top of the receiver shall be removed by agitation with the fine wire. When the volume of water in the receiver is constant the source of heat shall be removed and the receiver and contents allowed to cool to room temperature. Any droplets of water adhering to the sides of the receiver shall be dislodged by means of the fine wire.

10.5 The volume of condensed water, in millilitres, measured in the graduated receiver, and in any measuring cylinder used, at room temperature after subtracting the volume of water, if any, placed in the receiver before distillation was commenced, shall be noted (V).

IS : 4332 (Part II) - 1967

11. CALCULATIONS

11.1 In the case of soil stabilized with a solid stabilizer, the moisture content w shall be calculated as a percentage of the dry soil plus stabilizer weight from the formula:

$$w = \frac{100 V}{W_1 - V} \text{ percent}$$

where

V = volume of condensed water in ml, and

W_1 = original weight of sample in g.

11.2 In the case of soil stabilized with a fluid stabilizer, the moisture content w shall be calculated as a percentage of the dry soil weight from the formula:

$$w = \frac{(100 + s) V}{W_1 - V}$$

where

s = the non-aqueous fluid stabilizer content of the stabilized soil expressed as a percentage of the dry soil weight.

12. REPORTING OF RESULTS

12.1 The results of the test shall be tabulated suitably. A recommended proforma is given in Appendix B.

12.2 The moisture content of the stabilized soil shall be reported to the nearest whole number.

A P P E N D I X A

(Clause 6.1)

**DETERMINATION OF MOISTURE CONTENT OF
STABILIZED SOIL**

(OVEN DRYING METHOD)

Operator.....

Job.....

Date.....

Stabilizer.....

1. Determination No.

2. Container No.

3. Weight of container with lid with wet
stabilized soil (W_2), g

4. Weight of container with lid with dry
stabilized soil(W_3), g

5. Weight of container (W_1), g

6. Weight of moisture ($W_2 - W_3$), g

7. Weight of dry stabilized soil ($W_3 - W_1$), g

8. Moisture content, w percent

9. Fluid stabilizer content, if any

10. Moisture content, w percent

11. Remarks

A P P E N D I X B

(*Clause 12.1*)

**DETERMINATION OF MOISTURE CONTENT OF
STABILIZED SOIL**

(DISTILLATION METHOD)

1. Determination No.

2. Still No.

3. Weight of wet stabilized soil, W_1 g

4. Volume of water added to the receiver,
if any, ml

5. Volume of water distilled, V ml

6. Moisture content, w percent

7. Fluid stabilizer content, if any

8. Moisture content, w percent

9. Remarks
