

IS : 2950 (Part I) - 1981

(Reaffirmed 1998)

Edition 3.1

(1988-12)

Indian Standard

**CODE OF PRACTICE FOR
DESIGN AND CONSTRUCTION OF RAFT
FOUNDATIONS**

PART I DESIGN

(Second Revision)

(Incorporating Amendment No. 1)

UDC 624.153.61:624.0:69.001.3

© BIS 2003

BUREAU OF INDIAN STANDARDS
MANAK BHAVAN, 9 BAHADUR SHAH ZAFAR MARG
NEW DELHI 110002

Price Group 6

Indian Standard

CODE OF PRACTICE FOR
DESIGN AND CONSTRUCTION OF RAFT
FOUNDATIONS

PART I DESIGN

(*Second Revision*)

Foundation Engineering Sectional Committee, BDC 43

Chairman

Representing

PROF DINESH MOHAN

Central Building Research Institute (CSIR),
Roorkee

Members

DR R. K. BHANDARI

Central Building Research Institute (CSIR),
Roorkee

SHRI DEVENDRA SHARMA (*Alternate*)

CHIEF ENGINEER

Calcutta Port Trust, Calcutta

SHRI S. GUHA (*Alternate*)

SHRI M. G. DANDAVATE

The Concrete Association of India, Bombay

SHRI N. C. DUGGAL (*Alternate*)

SHRI R. K. DAS GUPTA

Simplex Concrete Piles (India) Pvt Ltd,
Calcutta

SHRI H. GUHA BISWAS (*Alternate*)

SHRI A. G. DASTIDAR

In personal capacity (5, *Hungerford Road*
121, *Hungerford Street, Calcutta*)

SHRI V. C. DESHPANDE

The Pressure Piling Co (I) Pvt Ltd, Bombay

DIRECTOR (CSMRS)

Central Water Commission, New Delhi

DEPUTY DIRECTOR (CSMRS) (*Alternate*)

SHRI A. H. DIVANJI

Asia Foundations and Construction Co Pvt
Ltd, Bombay

SHRI A. N. JANGLE (*Alternate*)

SHRI A. GHOSHAL

Stup Consultants Ltd, Bombay

PROF GOPAL RANJAN

University of Roorkee, Roorkee

DR JAGDISH NARAIN

Indian Geotechnic Society, New Delhi

PROF SWAMI SARAN (*Alternate*)

(*Continued on page 2*)

© BIS 2003

BUREAU OF INDIAN STANDARDS

This publication is protected under the *Indian Copyright Act* (XIV of 1957) and reproduction in whole or in part by any means except with written permission of the publisher shall be deemed to be an infringement of copyright under the said Act.

IS : 2950 (Part I) - 1981

(Continued from page 1)

<i>Members</i>	<i>Representing</i>
SHRI G. S. JAIN SHRI ASHOK KUMAR JAIN (<i>Alternate</i>)	G. S. Jain & Associates, Roorkee
JOINT DIRECTOR (D) SHRI SUNIL BERY (<i>Alternate</i>)	National Buildings Organisation, New Delhi
JOINT DIRECTOR RESEARCH (SM), RDSO JOINT DIRECTOR RESEARCH (B & S), RDSO (<i>Alternate</i>)	Ministry of Railways
DR R. K. KATTI	Indian Institute of Technology, Bombay
SHRI S. R. KULKARNI SHRI S. ROY (<i>Alternate</i>)	M. N. Dastur & Co Pvt Ltd, Calcutta
SHRI O. P. MALHOTRA	Public Works Department, Chandigarh
SHRI A. P. MATHUR	Central Warehousing Corporation, New Delhi
SHRI V. B. MATHUR	Machenzies Limited, Bombay
SHRI T. K. D. MUNSI SHRI M. IYENGAR (<i>Alternate</i>)	Engineers India Limited, New Delhi
SHRI Y. V. NARASIMHA RAO	Bokaro Steel Plant (Steel Authority of India), Bokaro
BRIG OMBIR SINGH LT-COL. K. P. ANAND (<i>Alternate</i>)	Engineer-in-Chief's Branch, Army Headquarters, New Delhi
SHRI B. K. PANTHAKY SHRI V. M. MADGE (<i>Alternate</i>)	The Hindustan Construction Company Limited, Bombay
SHRI M. R. PUNJA SHRI S. MUKHERJEE (<i>Alternate</i>)	Cemindia Co Ltd, Bombay
SHRI N. E. V. RAGHVAN	The Braithwaite Burn & Jessop Construction Co Ltd, Calcutta
SHRI A. A. RAJU	Vijayanagar Steel Plant (SAI), New Delhi
DR V. V. S. RAO	Nagadi Consultants Pvt Ltd, New Delhi
SHRI ARJUN RIJHSINGHANI SHRI O. S. SRIVASTAVA (<i>Alternate</i>)	Cement Corporation of India, New Delhi
DR A. SARGUNAN SHRI S. BOOMINATHAN (<i>Alternate</i>)	College of Engineering, Guindy
SHRI K. R. SAXENA	Public Works Department, Government of Andhra Pradesh, Hyderabad
DR S. P. SHRIVASTAVA DR R. KAPUR (<i>Alternate</i>)	United Technical Consultants Pvt Ltd, New Delhi
SHRI T. N. SUBBA RAO SHRI S. A. REDDI (<i>Alternate</i>)	Gammon India Limited, Bombay
SHRI N. SIVAGURU SHRI D. V. SIKKA (<i>Alternate</i>)	Ministry of Shipping and Transport, New Delhi
SUPERINTENDING ENGINEER (DESIGNS) EXECUTIVE ENGINEER (DESIGNS) V (<i>Alternate</i>)	Central Public Works Department, New Delhi

(Continued on page 24)

Indian Standard
CODE OF PRACTICE FOR
DESIGN AND CONSTRUCTION OF RAFT
FOUNDATIONS
PART I DESIGN
(*Second Revision*)

0. FOREWORD

0.1 This Indian Standard (Part I) was adopted by the Indian Standards Institution on 5 October 1981, after the draft finalized by the Foundation Engineering Sectional Committee had been approved by the Civil Engineering Division Council.

0.2 Raft foundation is a substructure supporting an arrangement of columns or walls in a row or rows and transmitting the loads to the soil by means of a continuous slab with or without depressions or openings. Such types of foundations are found useful where soil has low bearing capacity. This standard was first published in 1965 and revised in 1973. In this revision, besides making its contents up-to-date, guidelines have been given to choose particular type of methods in particular situations and giving reference to finite difference method which will be covered at a later stage.

0.3 This edition 3.1 incorporates Amendment No. 1 (December 1988). Side bar indicates modification of the text as the result of incorporation of the amendment.

0.4 For the purpose of deciding whether a particular requirement of this standard is complied with, the final value, observed or calculated, expressing the result of a test, shall be rounded off in accordance with IS : 2-1960*. The number of significant places retained in the rounded off value should be same as that of the specified value in this standard.

1. SCOPE

1.1 This standard (Part I) covers the design of raft foundation based on conventional method (for rigid foundation) and simplified methods (flexible foundation) for residential and industrial buildings, store-houses, silos, storage tanks, etc, which have mainly vertical and evenly distributed loads.

*Rules for rounding off numerical values (*revised*).

IS : 2950 (Part I) - 1981

2. TERMINOLOGY

2.1 For the purpose of this standard, the definitions of terms given in IS : 2809-1972* shall apply.

3. NECESSARY INFORMATION

3.1 For satisfactory design and construction of a raft foundation, the following information is necessary:

- a) *Site Plan* — Site plan showing the location of the proposed as well as neighbouring structure.
- b) Building plan and vertical cross-sections showing different floor levels, ducts and openings, etc, layout of load bearing walls, columns, shear walls, etc.
- c) Loading conditions preferably shown on a schematic plan indicating design combination of loads transmitted to the foundation.
- d) *Environmental Factors* — Information relating to geologic history of the area, seismicity of the region, hydrological information indicating ground water conditions and its seasonal variations, climatic factors like vulnerability of the site to sudden flooding by surface run-off, erosion, etc.
- e) *Geotechnical Information* — Giving subsurface profile with stratification details (see IS : 1892-1979†), engineering properties of the founding strata, namely, index properties, effective shear parameters determined under appropriate drainage conditions, compressibility characteristics, swelling properties, results of field tests like static and dynamic penetration tests, pressure meter tests, etc.
- f) *Modulus of Elasticity and Modulus of Subgrade Reaction* — Appendix A enumerates the methods of determination of modulus of elasticity (E_s) and Poisson's ratio (μ). The modulus of subgrade reaction (k) may be determined in accordance with Appendix B.
- g) Limiting values of the angular distortion and differential settlement, the superstructure can withstand (see IS : 1904-1987‡).
- h) A review of the performance of a similar structure, if any, in the locality.

*Glossary of terms and symbols relating to soil engineering (*first revision*).

†Code of practice for subsurface investigations for foundations (*first revision*).

‡Code of practice for design and construction of foundations in soils: General requirements (*third revision*).

j) Information necessary to assess the possible effects of the new structure on the existing structures in the neighbourhood.

k) Proximity of mines or major storage reservoirs to the site.

3.2 Parameters for the Analysis — These are obtained by averaging the parameters (*see* 3.1) which can be determined only for relatively less number of points of the foundation soil. The accuracy with which the average values represent the actual conditions is of decisive importance for the final results.

4. DESIGN CONSIDERATIONS

4.1 Choice of Raft Type

4.1.1 For fairly small and uniform column spacing and when the supporting soil is not too compressible, a flat concrete slab having uniform thickness throughout (a true mat) is most suitable (*see* Fig. 1A).

4.1.2 The slab may be thickened under heavily loaded columns to provide adequate strength for shear and negative moment. Pedestals may also be provided in such cases (*see* Fig. 1B).

4.1.3 A slab and beam type of raft is likely to be more economical for large column spacing and unequal column loads, particularly when the supporting soil is very compressible (*see* Fig. 1C).

4.1.4 For very heavy structures, provision of cellular raft or rigid frames consisting of slabs and basement walls may be considered.

4.2 Allowable Bearing Pressure — The allowable bearing pressure shall be determined in accordance with IS : 6403-1981*.

4.2.1 In granular soils, the ultimate bearing capacity of rafts is generally very large. However, for rafts placed at considerable depth (for example basement rafts), the possibility of punching mode of failure should be investigated. The influence of soil compressibility and related scale effects should also be assessed.

4.2.2 For rafts on cohesive soils stability against deep seated failures shall be analysed.

4.2.3 In cohesive soils, the effect of long term settlement due to consideration shall be taken into consideration.

4.3 Depth of Foundation — The depth of foundation shall generally be not less than 1 m.

*Code of practice for determination of bearing capacity of shallow foundation (*first revision*).

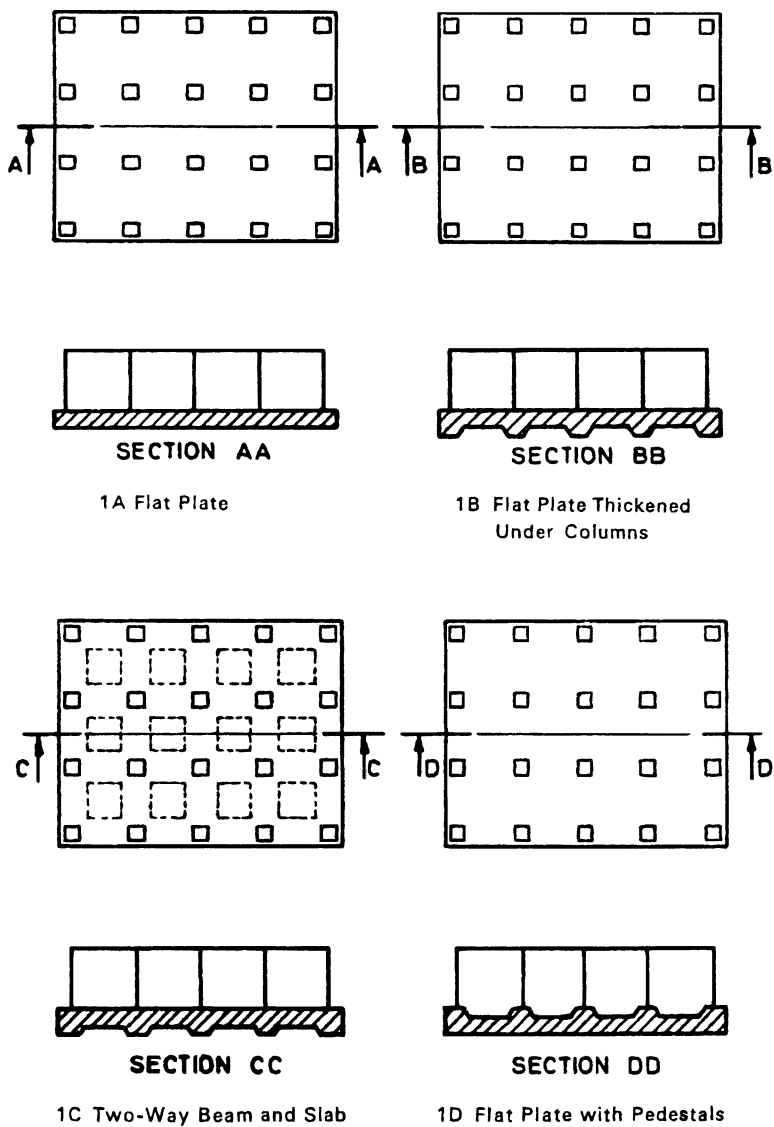

FIG. 1 COMMON TYPES OF RAFT FOUNDATIONS

4.4 Sub-soil Water Pressure — The uplift due to the sub-soil water shall be considered in the design.

4.4.1 All construction below the ground water level shall be checked for flotation.

4.5 General

4.5.1 *Dimensional Parameters* — The size and shape of the foundation adopted affect the magnitude of subgrade modulus and long term deformation of the supporting soil and this, in turn, influence the distribution of contact pressure. This aspect shall be taken into consideration in the analysis.

4.5.2 *Eccentricity of Loading* — A raft generally occupies the entire area of the building and often it is not feasible and rather uneconomical to proportion it coinciding the centroid of the raft with the line of action of the resultant force. In such cases, the effect of the eccentricity on contact pressure distribution shall be taken into consideration.

4.5.3 *Properties of the Supporting Soil* — Distribution of contact pressure underneath a raft is affected by the physical characteristics of the soil supporting it. Considerations must be given to the increased contact pressure developed along the edges of the foundation on cohesive soils and the opposite effect on granular soils. Long term consolidation of deep soil layers shall be taken into account in the analysis. This may necessitate evaluation of contact pressure distribution both immediately after construction and after completion of the consolidation process. The design must be based on the worst conditions.

4.5.4 *Rigidity of the Foundation* — Rigidity of the foundation tends to iron out uneven deformations and thereby modifies the contact pressure distribution. High order of rigidity is characterized by large moments and relatively small, uniform settlements. A rigid foundation may also generate high secondary stresses in structural members. The effects of rigidity shall be taken into account in the analysis.

4.5.5 *Rigidity of the Superstructure* — Free response of the foundations to soil deformation is restricted by the rigidity of the superstructure. In the extreme case, a stiff structure may force a flexible foundation to behave as rigid. This aspect shall be considered to evaluate the validity of the contact pressure distribution.

4.6 Heavy Vibratory Loads — Foundations subjected to heavy vibratory loads should preferably be isolated.

IS : 2950 (Part I) - 1981

4.7 Expansion Joints — In case the structure supported by the raft consists of several parts with varying heights and loads, it is advisable to provide expansion joints between these parts. Joints may also be provided wherever there is a change in the direction of the raft.

5. METHODS OF ANALYSIS

5.0 The essential task in the analysis of a raft foundation is the determination of the distribution of contact pressure underneath the raft which is a complex function of the rigidity of the superstructure, raft itself and the supporting soil, and cannot except in very simple cases, be determined with exactitude. This necessitates a number of simplifying assumptions to make the problem amenable to analysis. Once the distribution of contact pressure is determined, design bending moments and shears can be computed based on statics. The following methods of analysis are suggested which are distinguished by the assumptions involved. Choice of a particular method should be governed by the validity of the assumptions in the particular case.

5.1 Rigid Foundation (Conventional Method) — This is based on the assumptions of linear distribution of contact pressure. The basic assumptions of this method are:

- a) The foundation is rigid relative to the supporting soil and the compressible soil layer is relatively shallow.
- b) The contact pressure variation is assumed as planar, such that the centroid of the contact pressure coincides with the line of action of the resultant force of all loads acting on the foundation.

5.1.1 This method may be used when either of the following conditions is satisfied:

- a) The structure behaves as rigid (due to the combined action of the superstructure and the foundation) with a relative stiffness factor $K > 0.5$ (for evaluation of K , see Appendix C).
- b) The column spacing is less than $1.75/\lambda$ (see Appendix C).

5.1.2 The raft is analysed as a whole in each of the two perpendicular directions. The contact pressure distribution is determined by the procedure outlined in Appendix D. Further analysis is also based on statics.

5.1.3 In cases of uniform conditions when the variations in adjacent column loads and column spacings do not exceed 20 percent of the higher value, the raft may be divided into perpendicular strips of widths equal to the distance between midspans and each strip may be analysed as an independent beam with known column loads and

known contact pressures. Such beams will not normally satisfy statics due to shear transfer between adjacent strips and the design may be based on suitable moment coefficients, or on moment distribution.

NOTE — On soft soils, for example, normally consolidated clays, peat, muck, organic silts, etc, the assumptions involved in the conventional method are commonly justified.

5.2 Flexible Foundation

5.2.1 Simplified Method— In this method, it is assumed that the subgrade consists of an infinite array of individual elastic springs each of which is not affected by others. The spring constant is equal to the modulus of subgrade reaction (k). The contact pressure at any point under the raft is, therefore, linearly proportional to the settlement at the point. This method may be used when the following conditions are satisfied (see Appendix E):

- a) The structure (combined action of superstructure and raft) may be considered as flexible (relative stiffness factor $K < 0.5$, see Appendix C).
- b) Variation in adjacent column load does not exceed 20 percent of the higher value.

5.2.1.1 General method— For the general case of a flexible foundation not satisfying the requirements of **5.2.1**, the method based on closed form solution of elastic plate theory may be used. This method is based on the theory of plates on winkler foundation which takes into account the restraint on deflection of a point provided by continuity of the foundation in orthogonal foundation. The distribution of deflection and contact pressure on the raft due to a column load is determined by the plate theory. Since the effect of a column load on an elastic foundation is damped out rapidly, it is possible to determine the total effect at a point of all column loads within the zone of influence by the method of super imposition. The computation of the effect at any point may be restricted to columns of two adjoining bays in all directions. The procedure is outlined in Appendix F.

NOTE — One of the recent general methods based on the above mentioned theory is numerical analysis by either finite difference method or finite element method. This method is used for accurate analysis of the raft foundation. The details of this method could be covered at a later stage.

6. STRUCTURAL DESIGN

6.1 The general design for loads, shrinkage, creep and temperature effects and provision of reinforcement and detailing shall conform to IS : 456-1978*, the foundation being considered as an inverted beam or slab.

*Code of practice for plain and reinforced concrete (*third revision*).

APPENDIX A

[Clause 3.1(f)]

DETERMINATION OF MODULUS OF ELASTICITY (E_s) AND POISSON'S RATIO (μ)

A-1. DETERMINATION OF MODULUS OF ELASTICITY (E_s)

A-1.1 The modulus of elasticity is a function of the composition of the soil, its void ratio, stress history and loading rate. In granular soils it is a function of the depth of the strata, while in cohesive soils it is markedly influenced by the moisture content. Due to its great sensitivity to sampling disturbance accurate evaluation of the modulus in the laboratory is extremely difficult. For general cases, therefore, determination of the modulus may be based on field tests (**A-2**). Where a properly equipped laboratory and sampling facility are available, E_s may be determined in the laboratory (*see* **A-3**).

A-2. FIELD DETERMINATION

A-2.1 The value of E_s shall be determined from plate load test given in IS : 1888-1982*.

$$E_s = qB \frac{(1 - \mu^2)}{s} I_w$$

where

- q = intensity of contact pressure,
- B = least lateral dimension of test plate,
- s = settlement,
- μ = Poisson's ratio,
- I_w = Influence factor, and
= 0.82 for a square plate.

A-2.1.1 The average value of E_s shall be based on a number of plate load tests carried out over the area, the number and location of the tests, depending upon the extent and importance of the structure.

A-2.1.2 *Effect of Size*— In granular soils, the value of E_s corresponding to the size of the raft shall be determined as follows:

$$E_s = E_p \frac{B_f}{B_p} \frac{(B_f + B_p)^2}{2B_f}$$

*Method of load test on soils (*second revision*).

where B_f , B_p represent sizes of foundation and plate and E_p is the modulus determined by the plate load test.

A-2.2 For stratified deposits or deposits with lenses of different materials, results of plate load test will be unreliable and static cone penetration tests may be carried out to determine E_s .

A-2.2.1 Static cone penetration tests shall be carried out in accordance with IS : 4968 (Part III)-1976*. Several tests shall be carried out at regular depth intervals up to a depth equal to the width of the raft and the results plotted to obtain an average value of E_s .

A-2.2.2 The value of E_s may be determined from the following relationship:

$$E_s = 2 C_{kd}$$

where

$$C_{kd} = \text{cone resistance in kgf/cm}^2.$$

A-3. LABORATORY DETERMINATION OF E_s

A-3.1 The value of E_s shall be determined by conducting triaxial test in the laboratory [see IS : 2720 (Part XI)-1971† and IS : 2720 (Part XII)-1981‡] on samples collected with least disturbances.

A-3.2 In the first phase of the triaxial test, the specimen shall be allowed to consolidate fully under an all-round confining pressure equal to the vertical effective overburden stress for the specimen in the field. In the second phase, after equilibrium has been reached, further drainage shall be prevented and the deviator stress shall be increased from zero value to the magnitude estimated for the field loading condition. The deviator stress shall then be reduced to zero and the cycle of loading shall be repeated.

A-3.3 The value of E_s shall be taken as the tangent modulus at the stress level equal to one-half the maximum deviator stress applied during the second cycle of loading.

*Method for subsurface sounding for soils: Part III Static cone penetration test (*first revision*).

†Methods of test for soils: Part XI Determination of shear strength parameters of a specimen tested in unconsolidated undrained triaxial compression without the measurement of pore water pressure.

‡Methods of test for soils: Part XII Determination of shear strength parameters of soils from consolidated undrained triaxial compression test with measurement of pore water pressure (*first revision*).

APPENDIX B

[Clause 3.1 (f)]

DETERMINATION OF MODULUS OF SUBGRADE REACTION

B-1. GENERAL

B-1.1 The modulus of subgrade reaction (k) as applicable to the case of load through a plate of size 30×30 cm or beams 30 cm wide on the soil is given in Table 1 for cohesionless soils and in Table 2 for cohesive soils. Unless more specific determination of k is done (see **B-2** and **B-3**), these values may be used for design of raft foundation in cases where the depth of the soil affected by the width of the footing may be considered isotropic and the extrapolation of plate load test results is valid.

TABLE 1 MODULUS OF SUBGRADE REACTION (k) FOR COHESIONLESS SOILS

SOIL CHARACTERISTIC		*MODULUS OF SUBGRADE REACTION (k) IN kg/cm^3	
Relative Density	Standard Penetration Test Value (N)	For Dry or Moist State	For Submerged State
(1)	(2)	(3)	(4)
Loose	< 10	1.5	0.9
Medium	10 to 30	1.5 to 4.7	0.9 to 2.9
Dense	30 and Over	4.7 to 18.0	2.9 to 10.8

*The above values apply to a square plate 30×30 cm or beams 30 cm wide.

TABLE 2 MODULUS OF SUBGRADE REACTION (k) FOR COHESIVE SOILS

SOIL CHARACTERISTIC		*MODULUS OF SUBGRADE REACTION (K_s) IN kg/cm^3
Consistency	Unconfined Compressive Strength, kg/cm^2	
(1)	(2)	(3)
Stiff	1 to 2	2.7
Very stiff	2 to 4	2.7 to 5.4
Hard	4 and over	5.4 to 10.8

*The values apply to a square plate 30×30 cm. The above values are based on the assumption that the average loading intensity does not exceed half the ultimate bearing capacity.

B-2. FIELD DETERMINATION

B-2.1 In cases where the depth of the soil affected by the width of the footing may be considered as isotropic, the value of k may be determined in accordance with IS : 9214-1979*. The test shall be carried out with a plate of size not less than 30 cm.

B-2.2 The average value of k shall be based on a number of plate load tests carried out over the area, the number and location of the tests depending upon the extent and importance of the structure.

B-3. LABORATORY DETERMINATION

B-3.1 For stratified deposits or deposits with lenses of different materials, evaluation of k from plate load test will be unrealistic and its determination shall be based on laboratory tests [see IS : 2720 (Part XI)-1971† and IS : 2720 (Part XII)-1981‡].

B-3.2 In carrying out the test, the continuing cell pressure may be so selected as to be representative of the depth of average stress influence zone (about $0.5 B$ to B).

B-3.3 The value of k shall be determined from the following relationship:

$$k = 0.65 \sqrt[12]{\frac{E_s B^4}{E I}} \cdot \frac{E_s}{1 - \mu^2} \cdot \frac{1}{B}$$

where

E_s = Modulus of elasticity of soil (see Appendix A),

E = Young's modulus of foundation material,

μ = Poisson's ratio of soil (see Appendix A), and

I = Moment of inertia of structure if determined or of the foundation.

B-3.4 In the absence of laboratory test data, appropriate values of E_s and μ may be determined in accordance with Appendix A and used in **B-3.2** for evaluation of k .

*Method of determination of subgrade reaction (k value) of soils in the field.

†Methods of test for soils: Part XI Determination of shear strength parameters of specimen tested in unconsolidated undrained triaxial compression without the measurement of pore water pressure.

‡Methods of test for soils: Part XII Determination of shear strength parameters of soil from consolidated undrained triaxial compression test with measurement of pore water pressure (*first revision*).

IS : 2950 (Part I) - 1981

B-4. CALCULATIONS

B-4.1 When the structure is rigid (*see* Appendix C), the average modulus of subgrade reaction may also be determined as follows:

$$k_s = \frac{\text{Average contact pressure}}{\text{Average settlement of the raft}}$$

APPENDIX C

(*Clauses 5.1.1, 5.2.1 and B-4.1*)

RIGIDITY OF SUPERSTRUCTURE AND FOUNDATION

C-1. DETERMINATION OF THE RIGIDITY OF THE STRUCTURE

C-1.1 The flexural rigidity EI of the structure of any section may be estimated according to the relation given below (*see also* Fig. 2):

$$EI = \frac{E_1 I_1 b^2}{2 H^2} + \sum E_2 I_b \left[1 + \frac{(I'_u + I'_l) b^2}{(I'_b + I'_u + I'_l) l^2} \right]$$

where

E_1 = modulus of elasticity of the infilling material (wall material) in kg/cm^2 ,

I_1 = moment of inertia of the infilling in cm^4 ,

b = length or breadth of the structure in the direction of bending,

H = total height of the infilling in cm,

E_2 = modulus of elasticity of frame material in kg/cm^2 ,

I_b = moment of inertia of the beam in cm^4 ,

$$I'_u = \frac{I_u}{h_u},$$

$$I'_l = \frac{I_l}{h_l},$$

$$I_b = \frac{I_b}{l},$$

l = spacing of the columns in cm,

h_u = length of the upper column in cm,

h_l = length of the lower column in cm,

$$I_f = \frac{I_f}{l},$$

I_u = moment of inertia of the upper column in cm^4 ,

I_l = moment of inertia of the lower column in cm^4 , and

I_f = moment of inertia of the foundation beam or raft in cm^4 .

NOTE — The summation is to be done over all the storeys, including the foundation beam or raft. In the case of the foundation, I_f replaces I_b and I_l becomes zero, whereas for the topmost beam, I_u becomes zero.

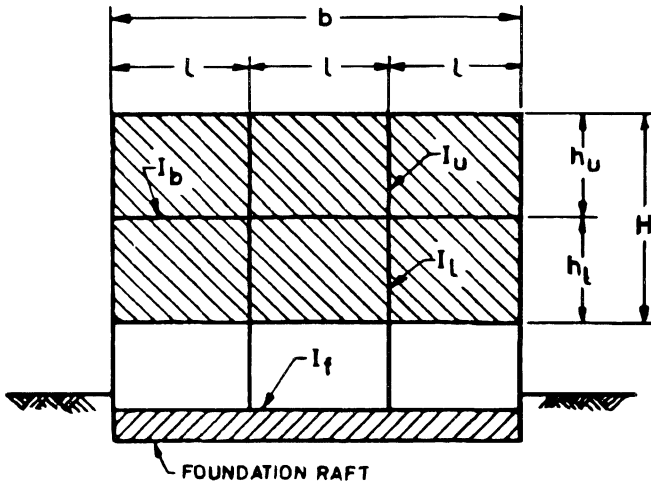

FIG. 2 DETERMINATION OF RIGIDITY OF A STRUCTURE

C-2. RELATIVE STIFFNESS FACTOR K

C-2.1 Whether a structure behaves as rigid or flexible depends on the relative stiffness of the structure and the foundation soil. This relation

IS : 2950 (Part I) - 1981

is expressed by the relative stiffness factor K given below:

a) For the whole structure
$$K = \frac{EI}{E_s b^3 a}$$

b) For rectangular rafts or beams
$$K = \frac{E}{12 E_s} \left(\frac{d}{b} \right)^3$$

c) For circular rafts
$$K = \frac{E}{12 E_s} \left(\frac{d}{2 R} \right)^3$$

where

EI = flexural rigidity of the structure over the length (a) in kg/cm^2 ,

E_s = modulus of compressibility of the foundation soil in kg/cm^2 ,

b = length of the section in the bending axis in cm,

a = length perpendicular to the section under investigation in cm,

d = thickness of the raft or beam in cm, and

R = radius of the raft in cm.

C-2.1.1 For $K > 0.5$, the foundation may be considered as rigid (see 5.1.1).

C-3. DETERMINATION OF CRITICAL COLUMN SPACING

C-3.1 Evaluation of the characteristics λ is made as follows:

$$\lambda = \sqrt[4]{\frac{kB}{4E_c I}}$$

where

k = modulus of subgrade reaction in kg/cm^3 for footing of width B in cm (see Appendix B).

B = width of raft in cm

E_c = modulus of elasticity of concrete in kgf/cm^2

I = moment of inertia of the raft in cm^4

APPENDIX D

(Clause 5.1.2)

**CALCULATION OF PRESSURE DISTRIBUTION BY
CONVENTIONAL METHOD****D-1. DETERMINATION OF PRESSURE DISTRIBUTION**

D-1.1 The pressure distribution (q) under the raft shall be determined by the following formula:

$$q = \frac{Q}{A'} \pm \frac{Qe'_y}{I_x} y \pm \frac{Qe'_x}{I_y} x$$

where

Q = total vertical load on the raft,

A' = total area of the raft,

e'_x, e'_y, I_x, I_y = eccentricities and moments of inertia about the principal axes through the centroid of the section, and

x, y = co-ordinates of any given point on the raft with respect to the x and y axes passing through the centroid of the area of the raft.

I_x, I_y, e'_x, e'_y may be calculated from the following equations:

$$I_x = I_x - \frac{I_{xy}^2}{I_y},$$

$$I_y = I_y - \frac{I_{xy}^2}{I_x},$$

$$e'_x = e_x - \frac{I_{xy}}{I_x} e_y, \text{ and}$$

$$e'_y = e_y - \frac{I_{xy}}{I_y} e_x$$

where

I_x, I_y = moment of inertia of the area of the raft respectively about the x and y axes through the centroid,

IS : 2950 (Part I) - 1981

$I_{xy} = \int xy dA$ for the whole area about x and y axes through the centroid, and

e_x, e_y = eccentricities in the x and y directions of the load from the centroid.

For a rectangular raft the equation simplifies to:

$$q = \frac{Q}{A} \left(1 \pm \frac{12 e_y y}{b^2} \pm \frac{12 e_x x}{a^2} \right)$$

where

a and b = the dimensions of the raft in the x and y directions respectively.

NOTE — If one or more of the values of (q) are negative, as calculated by the above formula, it indicates that the whole area of foundation is not subject to pressure and only a part of the area is in contact with the soil, and the above formula will still hold good, provided appropriate values of I_x, I_y, I_{xy}, e_x and e_y are used with respect to the area in contact with the soil instead of the whole area.

APPENDIX E

(Clause 5.2.1)

CONTACT PRESSURE DISTRIBUTION AND MOMENTS BELOW FLEXIBLE FOUNDATION

E-1. CONTACT PRESSURE DISTRIBUTION

E-1.1 The distribution of contact pressure is assumed to be linear with maximum value attained under the columns and minimum at mid span.

E-1.2 The contact pressure for the full width of the strip under an interior column load located at point i (p_i) can be determined as (see Fig. 3B):

$$p_i = \frac{5P_i}{\bar{l}} + \frac{48M_i}{\bar{l}^2}$$

where

\bar{l} = average length of adjacent span (m),

P_i = column load at point i (t), and

M_i = moment under an interior columns located at i .

E-1.3 The minimum contact pressure for the full width of the strip at the middle of the adjacent spans p_{ml} and p_{mr} can be determined as (see Fig. 3A):

$$p_{ml} = 2P_i \frac{l_r}{l_l \bar{l}} - p_i \frac{\bar{l}}{l_l}$$

$$p_{mr} = 2P_i \frac{l_l}{l_r \bar{l}} - p_i \frac{\bar{l}}{l_r}$$

$$p_m = \frac{p_{mr} + p_{ml}}{2}$$

where l_r , l_l as shown in Fig. 3A.

E-1.4 If **E-2.3(a)** governs the moment under the exterior columns, contact pressures under the exterior columns and at end of the strip p_e and p_c can be determined as (see Fig. 3C):

$$p_e = \frac{4P_e + \frac{6M_e}{C} - p_m l_1}{C + l_1}$$

$$p_c = -\frac{3M_e}{C^2} - \frac{p_e}{2}$$

where P_e , p_m , M_e , l_1 , C as shown in Fig. 3C.

E-1.5 If **E-2.3 (b)** governs the moment under the exterior columns, the contact pressures p_e and p_c are determined as (see Fig. 3C):

$$p_e = p_c = \frac{4P_e - p_m l_1}{4C + l_1}$$

E-2. BENDING MOMENT DIAGRAM

E-2.1 The bending moment under an interior column located at i (see Fig. 3A) can be determined as:

$$M_i = -\frac{P_i}{4\lambda} (0.24\lambda \bar{l} + 0.16)$$

E-2.2 The bending moment at midspan is obtained as (see Fig. 3B):

$$M_m = M_o + M_j$$

where

M_o = moment of simply supported beam

$$= \frac{l^2}{48} [p_i (l) + 4 \bar{p}_m + p_i (r)]$$

where l , $p_i (l)$, $p_i (r)$, \bar{p}_m are as shown in Fig. 3B.

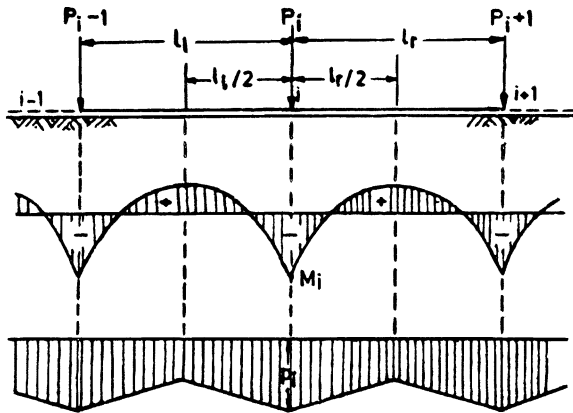

3A Moment and Pressure Distribution at Interior Column

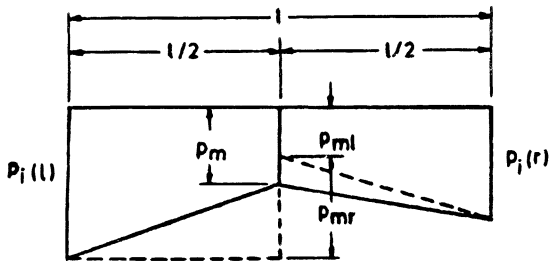

3B Pressure Distribution Over an Interior Span

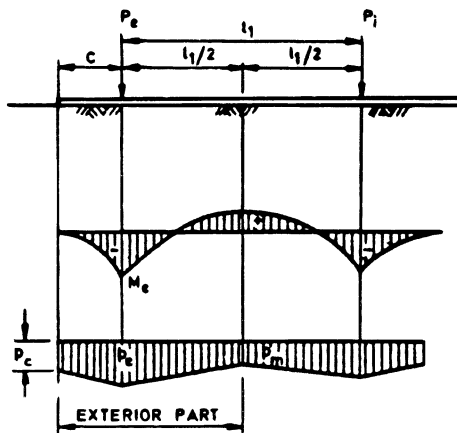

3C. Moment and Pressure Distribution at Exterior Column

FIG. 3 MOMENT AND PRESSURE DISTRIBUTION AT COLUMNS

E-2.3 The bending moment M_e under exterior columns can be determined as the least of (see Fig. 3C):

a) $\frac{P_c}{4\lambda} (0.13\lambda I_1 + 1.06 \lambda C - 0.50)$

b) $-\frac{(4 P_e - p_m I_1) C^2}{4C + I_1} \frac{C^2}{2}$

APPENDIX F

(Clause 5.2.1.1)

FLEXIBLE FOUNDATION — GENERAL CONDITION

F-1. CLOSED FORM SOLUTION OF ELASTIC PLATE THEORY

F-1.1 For a flexible raft foundation with nonuniform column spacing and load intensity, solution of the differential equation governing the behaviour of plates on elastic foundation (Winkler Type) gives radial moment (M_r) tangential moment (M_t) and deflection (w) at any point by the following expressions:

$$M_r = -\frac{P}{4} \left(Z_4 \left(\frac{r}{L} \right) - (1 - \mu) \frac{Z_3' \left(\frac{r}{L} \right)}{\left(\frac{r}{L} \right)} \right)$$

$$M_t = -\frac{P}{4} \left(\mu Z_4 \left(\frac{r}{L} \right) + (1 - \mu) \frac{Z_3' \left(\frac{r}{L} \right)}{\left(\frac{r}{L} \right)} \right)$$

$$w = \frac{PL^3}{4D} Z_3 \left(\frac{r}{L} \right)$$

where

P = column load;

r = distance of the point under investigation from column load along radius;

IS : 2950 (Part I) - 1981

L = radius of effective stiffness;

$$\sqrt[4]{\frac{D}{k}}$$

k = modulus of subgrade reaction for footing of width B ;

D = flexural rigidity of the foundation;

$$= \frac{Et^2}{12(1-\mu^2)}$$

t = raft thickness;

E = modulus of elasticity of the foundation material;

μ = poisson's ratio of foundation material; and

$Z_3\left(\frac{r}{L}\right), Z_3\left(\frac{r}{L}\right), Z_4\left(\frac{r}{L}\right)$ = functions of shear, moment and deflection (see Fig. 4).

F-1.2 The radial and tangential moments can be converted to rectangular co-ordinates:

$$M_x = M_r \cos^2 \phi + M_t \sin^2 \phi$$

$$M_y = M_r \sin^2 \phi + M_t \cos^2 \phi$$

where

ϕ = is the angle with x axis to the line joining origin to the point under consideration.

F-1.3 The shear Q per unit width of raft can be determined by:

$$Q = - \frac{P}{4L} Z_4 \left(\frac{r}{L} \right)$$

where

Z_4 = function for shear (see Fig. 4).

F-1.4 When edge of the raft is located within the radius of influence, the following corrections are to be applied. Calculate moments and shears perpendicular to the edge of the raft within the radius of influence, assuming the raft to be infinitely large. Then apply opposite and equal moments and shears on the edge of the mat. The method for beams on elastic foundation may be used.

F-1.5 Finally all moments and shears calculated for each individual column and walls are superimposed to obtain the total moment and shear values.

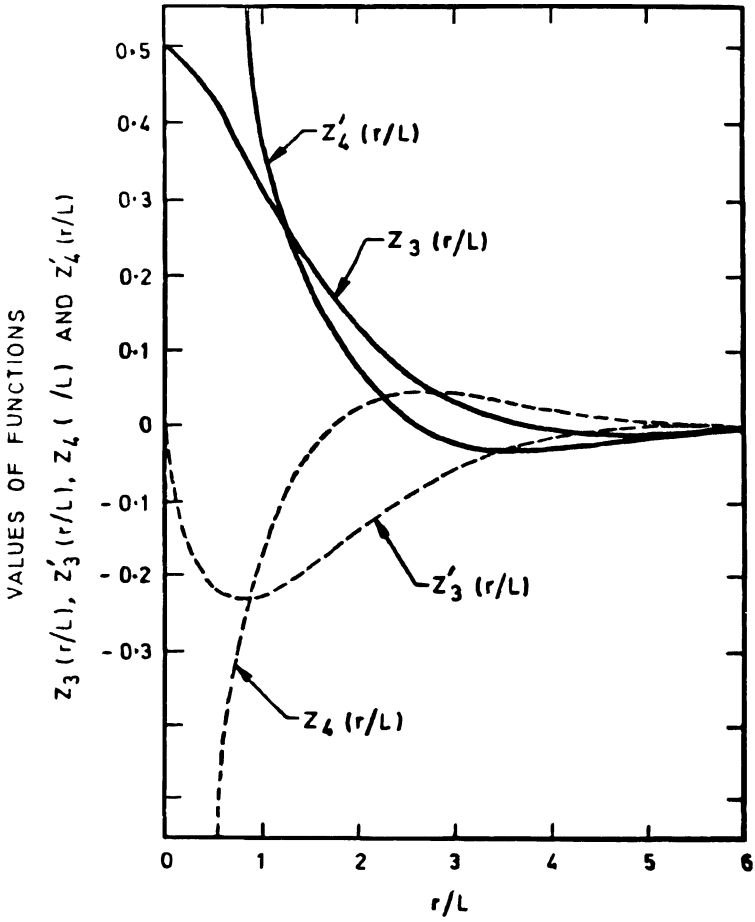

FIG. 4 FUNCTIONS FOR SHEAR MOMENT AND DEFLECTION

IS : 2950 (Part I) - 1981

(Continued from page 2)

Members

SHRI M. D. TAMBEKAR
DR A. VARADARAJAN
DR R. KANIRAJ (*Alternate*)
SHRI G. RAMAN,
Director (Civ Engg)

Representing

Bombay Port Trust, Bombay
Indian Institute of Technology, New Delhi
Director General, BIS (*Ex-officio Member*)

Secretary

SHRI K. M. MATHUR
Deputy Director (Civ Engg), BIS

Bearing Capacity of Foundation Subcommittee, BDC 43

Convener

SHRI S. GUHA

Calcutta Port Trust, Calcutta

Members

DEPUTY DIRECTOR STANDARDS
(B & S), CB-II
EXECUTIVE ENGINEER (DESIGN) V
SHRI T. N. MUKHERJEE
SHRI B. G. RAO
SHRI AMAR SINGH (*Alternate*)
SHRI K. R. SAXENA
SHRI O. S. SRIVASTAVA
SHRI S. K. CHATTERJEE (*Alternate*)
DR SWAMI SARAN

Research, Designs & Standards Organization,
Lucknow
Central Public Works Department, New Delhi
Martin & Burns Co Ltd, Calcutta
Central Building Research Institute, Roorkee
Engineering Research Laboratories,
Hyderabad
Cement Corporation of India, New Delhi
University of Roorkee, Roorkee

Bureau of Indian Standards

BIS is a statutory institution established under the *Bureau of Indian Standards Act, 1986* to promote harmonious development of the activities of standardization, marking and quality certification of goods and attending to connected matters in the country.

Copyright

BIS has the copyright of all its publications. No part of these publications may be reproduced in any form without the prior permission in writing of BIS. This does not preclude the free use, in the course of implementing the standard, of necessary details, such as symbols and sizes, type or grade designations. Enquiries relating to copyright be addressed to the Director (Publications), BIS.

Review of Indian Standards

Amendments are issued to standards as the need arises on the basis of comments. Standards are also reviewed periodically; a standard along with amendments is reaffirmed when such review indicates that no changes are needed; if the review indicates that changes are needed, it is taken up for revision. Users of Indian Standards should ascertain that they are in possession of the latest amendments or edition by referring to the latest issue of 'BIS Catalogue' and 'Standards : Monthly Additions'.

This Indian Standard has been developed by Technical Committee : BDC 43

Amendments Issued Since Publication

Amend No.	Date of Issue
Amd. No. 1	December 1988

BUREAU OF INDIAN STANDARDS

Headquarters:

Manak Bhavan, 9 Bahadur Shah Zafar Marg, New Delhi 110002.
Telephones: 323 01 31, 323 33 75, 323 94 02

Telegrams: Manaksanstha
(Common to all offices)

Regional Offices:

	Telephone
Central : Manak Bhavan, 9 Bahadur Shah Zafar Marg NEW DELHI 110002	{ 323 76 17 323 38 41
Eastern : 1/14 C. I. T. Scheme VII M, V. I. P. Road, Kankurgachi KOLKATA 700054	{ 337 84 99, 337 85 61 337 86 26, 337 91 20
Northern : SCO 335-336, Sector 34-A, CHANDIGARH 160022	{ 60 38 43 60 20 25
Southern : C. I. T. Campus, IV Cross Road, CHENNAI 600113	{ 235 02 16, 235 04 42 235 15 19, 235 23 15
Western : Manakalaya, E9 MIDC, Marol, Andheri (East) MUMBAI 400093	{ 832 92 95, 832 78 58 832 78 91, 832 78 92
Branches : AHMEDABAD. BANGALORE. BHOPAL. BHUBANESHWAR. COIMBATORE. FARIDABAD. GHAZIABAD. GUWAHATI. HYDERABAD. JAIPUR. KANPUR. LUCKNOW. NAGPUR. NALAGARH. PATNA. PUNE. RAJKOT. THIRUVANANTHAPURAM. VISHAKHAPATNAM	