

IS : 2720 (Part XXXVII) - 1976

Indian Standard

METHODS OF TEST FOR SOILS

PART XXXVII DETERMINATION OF SAND EQUIVALENT
VALUE OF SOILS AND FINE AGGREGATES

(First Reprint FEBRUARY 1987)

UDC 624.131.212/.216:620:1



© Copyright 1976

INDIAN STANDARDS INSTITUTION
MANAK BHAVAN, 9 BAHADUR SHAH ZAFAR MARG
NEW DELHI 110002

Indian Standard

METHODS OF TEST FOR SOILS

PART XXXVII DETERMINATION OF SAND EQUIVALENT VALUE OF SOILS AND FINE AGGREGATES

Soil Engineering Sectional Committee, BDC 23

Chairman

PROF DINESH MOHAN

Representing

Central Building Research Institute (CSIR),
Roorkee

Members

PROF ALAM SINGH	University of Jodhpur
LT-COL AVTAR SINGH	Engineer-in-Chief's Branch, Army Headquarters
MAJ R. R. SUDHINDRA (<i>Alternate</i>)	
DR A. BANERJEE	Cementation Co Ltd, Bombay
SHRI S. GUPTA (<i>Alternate</i>)	
SHRI K. N. DADINA	In personal capacity (<i>P-820 New Alipore, Calcutta</i>)
SHRI A. G. DASTIDAR	In personal capacity [<i>Inter-State Equipment (P) Ltd,</i> <i>3/1 Loudon Street, Calcutta</i>]
SHRI R. L. DEWAN	Irrigation Research Institute, Khagaul, Patna
DR G. S. DHILLON	Indian Geotechnical Society, New Delhi
DIRECTOR	Indian Institute of Technology, New Delhi
DR SHASHI K. GULHATI (<i>Alternate</i>)	
DIRECTOR	Irrigation & Power Research Institute, Amritsar
RESEARCH OFFICER (GEOTECH- NICAL SECTION) (<i>Alternate</i>)	
DIRECTOR (CSMRS)	Central Water Commission, New Delhi
DEPUTY DIRECTOR (CSMRS) (<i>Alternate</i>)	
SHRI A. H. DIVANJI	Rodio Foundation Engineering Ltd; and Hazarat & Co, Bombay
SHRI A. N. JANGLE (<i>Alternate</i>)	
SHRI V. G. HEGDE	National Buildings Organization, New Delhi
SHRI S. H. BALCHANDANI (<i>Alternate</i>)	
JOINT DIRECTOR RESEARCH (FE), RDSO	Railway Board (Ministry of Railways)
DEPUTY DIRECTOR RESEARCH, SOIL MECHANICS, RDSO (<i>Alternate</i>)	
SHRI O. P. MALHOTRA	Public Works Department, Government of Punjab
SHRI J. S. MARYA	Roads Wing (Ministry of Shipping & Transport)
SHRI N. SEN (<i>Alternate</i>)	

(Continued on page 2)

© Copyright 1976

INDIAN STANDARDS INSTITUTION

This publication is protected under the *Indian Copyright Act* (XIV of 1957) and reproduction in whole or in part by any means except with written permission of the publisher shall be deemed to be an infringement of copyright under the said Act.

IS : 2720 (Part XXXVII) - 1976

(Continued from page 1)

<i>Members</i>	<i>Representing</i>
SHRI G. D. MATHUR	Public Works Department, Government of Uttar Pradesh, Lucknow
SHRI D. C. CHATURVEDI (<i>Alternate</i>)	
SHRI M. A. MEHTA	Concrete Association of India, Bombay
SHRI T. M. MENON (<i>Alternate</i>)	
SHRI T. K. NATARAJAN	Central Road Research Institute (CSIR), New Delhi
REPRESENTATIVE RESEARCH OFFICER	Hindustan Construction Co Ltd, Bombay Buildings & Roads Research Laboratory, Public Works Department, Government of Punjab, Chandigarh
SHRI K. R. SAXENA	Engineering Research Laboratory, Hyderabad
SECRETARY	Central Board of Irrigation & Power, New Delhi
DEPUTY SECRETARY (<i>Alternate</i>)	
DR SHAMSHER PRAKASH	University of Roorkee
SHRI H. D. SHARMA	Irrigation Research Institute, Roorkee
SUPERINTENDING ENGINEER (PLANNING & DESIGN CIRCLE)	Concrete & Soil Research Laboratory, Public Works Department, Government of Tamil Nadu, Madras
EXECUTIVE ENGINEER (INCHARGE, SOIL MECHANICS & RESEARCH DIVISION) (<i>Alternate</i>)	
SHRI C. G. SWAMINATHAN	Institution of Engineers (India), Calcutta
SHRI H. C. VERMA	All India Instrument Manufacturers & Dealers Association, Bombay
SHRI V. K. VASUDEVAN (<i>Alternate</i>)	
SHRI D. AJITHA SIMHA, Director (Civ Engg)	Director General, ISI (<i>Ex-officio Member</i>)

Secretary

SHRI G. RAMAN
Deputy Director (Civ Engg), ISI

Soil Testing Procedures and Equipment Subcommittee, BDC 23 : 3

<i>Convener</i>	
PROF ALAM SINGH	University of Jodhpur
<i>Members</i>	
SHRI AMAR SINGH	Central Building Research Institute (CSIR), Roorkee
LT-COL AVTAR SINGH	Engineer-in-Chief's Branch, Army Headquarters
MAJ R. R. SUDHINDRA (<i>Alternate</i>)	
SHRI N. K. BERRY	Beas Dams Project, Talwara Township
SHRI K. S. PREM (<i>Alternate</i>)	
DR R. K. BHANDARI	Central Road Research Institute (CSIR), New Delhi
SHRI T. N. BHARGAWA	Roads Wing (Ministry of Shipping & Transport)
SHRI A. S. BISHNOI (<i>Alternate</i>)	
DR A. K. CHATTERJEE	Public Works Department, Government of Uttar Pradesh, Lucknow
DR B. L. DHAWAN (<i>Alternate</i>)	

(Continued on page 15)

Indian Standard

METHODS OF TEST FOR SOILS

PART XXXVII DETERMINATION OF SAND EQUIVALENT VALUE OF SOILS AND FINE AGGREGATES

0. FOREWORD

0.1 This Indian Standard (Part XXXVII) was adopted by the Indian Standards Institution on 16 February 1976, after the draft finalized by the Soil Engineering Sectional Committee had been approved by the Civil Engineering Division Council.

0.2 The term 'sand equivalent' expresses the concept that most granular soils and fine aggregates are mixtures of desirable coarse particles, sand and generally undesirable clay or plastic fines and dust. This test is not intended to replace the test covered by IS : 2720 (Part IV)-1975*.

0.3 This test assigns an empirical value to the relative amount, fineness and character of claylike material present in the test specimen. A minimum sand equivalent value may be specified to limit the permissible quantity of claylike fines in an aggregate. This test provides a rapid field method for determining changes in the quality of aggregates during production or placement.

0.4 In the formulation of this standard due weightage has been given to international co-ordination among the standards and practices prevailing in different countries in addition to relating it to the practices in the field in this country. This has been met by deriving assistance from the following publications :

A89.22A-1973 Methods of testing soils for engineering purposes :
Test 22A — Sand equivalent of aggregate and soil using a power-operated shaker. Standards Association of Australia.

ASTM D 2419-74 Standard method of test for sand equivalent value of soils and fine aggregate. American Society for Testing and Materials.

0.5 In reporting the results of a test or analysis made in accordance with this standard, if the final value, observed or calculated, is to be rounded off, it shall be done in accordance with IS : 2-1960†.

*Methods of test for soils: Part IV Grain size analysis (*first revision*).

†Rules for rounding off numerical values (*revised*).

1. SCOPE

1.1 This standard (Part XXXVII) covers the method for the determination of sand equivalent value of soils. This indicates, under standard conditions, the relative proportions of claylike or plastic fines and dusts in granular soils and fine aggregates that pass 4.75-mm IS Sieve. This method is intended to serve as a rapid field-correlation test.

2. GENERAL PRECAUTIONS

2.1 Maintain the temperature of the working solution at $27 \pm 3^{\circ}\text{C}$ during the performance of this test.

2.1.1 If field conditions preclude the maintenance of the temperature range, frequent referee samples should be submitted to a laboratory where proper temperature control is possible. It is also possible to establish temperature correction curves for each material being tested where proper temperature control is not possible. However, no general correction curve should be utilized for several materials even within a narrow range of sand equivalent values. Samples that meet the minimum sand equivalent requirement at a working solution temperature below the recommended range need not be subjected to referee testing.

2.2 Perform the test at a location free from vibration. Excessive vibration may cause the suspended material to settle at a greater rate than normal.

2.3 Do not expose the plastic cylinders to direct sunlight any more than is necessary.

2.4 Occasionally it may be necessary to remove a fungus growth from the working calcium chloride solution container and from the inside of the flexible tubing and irrigator tube. This fungus can easily be seen as a slimy substance in the solution.

2.4.1 To remove this growth, prepare a cleaning solvent by diluting sodium hypochlorite solution (household chlorine bleach) with an equal quantity of water.

2.4.2 Fill the solution container with the prepared cleaning solvent, allow about 1 litre of the cleaning solvent to flow through the siphon assembly and irrigator tube, then place the pinch clamp on the end of the tubing to cut off the flow of solvent and to hold the solvent in the tube. Refill the container and allow to stand overnight.

2.4.3 After soaking, allow the cleaning solvent to flow out through the siphon assembly and irrigator tube.

2.4.4 Remove the siphon assembly from the solution container and rinse both with clear water. The irrigator tube and siphon assembly can be rinsed easily by attaching a hose between the tip of the irrigator tube and water faucet and backwashing fresh water through the tube.

2.5 Occasionally the holes in the tip of the irrigator tube may become clogged by a particle of sand. If the obstruction cannot be freed by any other method, use a pin or other sharp object to force it out using extreme care not to enlarge the size of the opening.

3. APPARATUS

3.1 Graduated Cylinder — of transparent acrylic plastic as shown in Fig. 1 having an inside diameter of 32 mm, a height of 430 mm, graduations up to 380 mm at 2 mm intervals, beginning at the bottom, and a rubber stopper to fit in mouth of the cylinder.

3.2 Irrigator Tube — as shown in Fig. 1, made of 6.4 mm outside diameter stainless steel tubing with one end closed to form a wedge-shaped point. Two holes of 1 mm diameter are drilled laterally through the flat side of the wedge near the point.

3.3 Siphon Assembly — as shown in Fig. 1, consisting of a 4-litre bottle, a 5-mm outside diameter copper bent tube 410 mm long, 1 220 mm of 3-mm inside diameter rubber tubing (pure gum or equal) with pinch clamp, a blow tube consisting of 50 mm of 5-mm diameter copper tube and 50 mm of 3-mm inside diameter rubber tube (blow hose), and a 2-hole rubber stopper to fit the graduated cylinder specified in **3.1**.

3.4 Weighted Foot Assembly — as shown in Fig. 1, consisting of a 6-mm diameter brass rod 445 mm long, threaded on both ends, a brass hexagonal foot of 17.5 mm side by 14 mm diameter, a cylindrical weight of 50 mm diameter and 53 mm height of cold-rolled steel and a nylon sand reading indicator of 28 mm diameter and 15 mm height. The weight is attached to the top end of the rod to give the assembly of the weight, rod and foot a total mass of $1\ 000 \pm 5$ g. The foot is attached to the lower end of the rod.

3.5 Measuring Can — 90 ± 5 ml capacity.

3.6 Sieve — 475- μ m IS Sieve, conforming to IS : 460 - 1962*.

3.7 Funnel — wide mouth, for transferring soil into the cylinder.

3.8 4-Litre Bottles — two, to store stock solution and working solution.

3.9 Flat Pan — for mixing.

3.10 Timing Device — reading in minutes and seconds.

3.11 Sand Equivalent Shaker — mechanical or manually operated.

3.11.1 Mechanical — having a throw of 200 ± 1 mm and operating at 175 ± 2 cycles per minute.

*Specification for test sieves (*revised*).

6

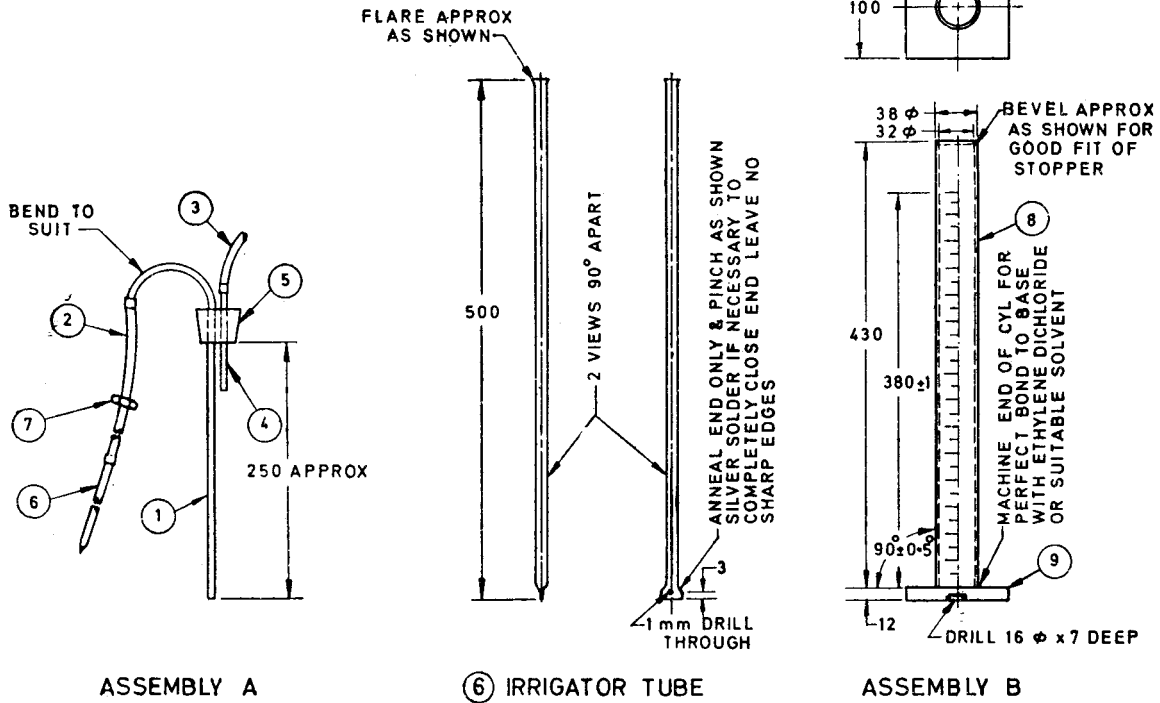

All dimensions in millimetres.

FIG. 1 SAND EQUIVALENT TEST APPARATUS—Contd

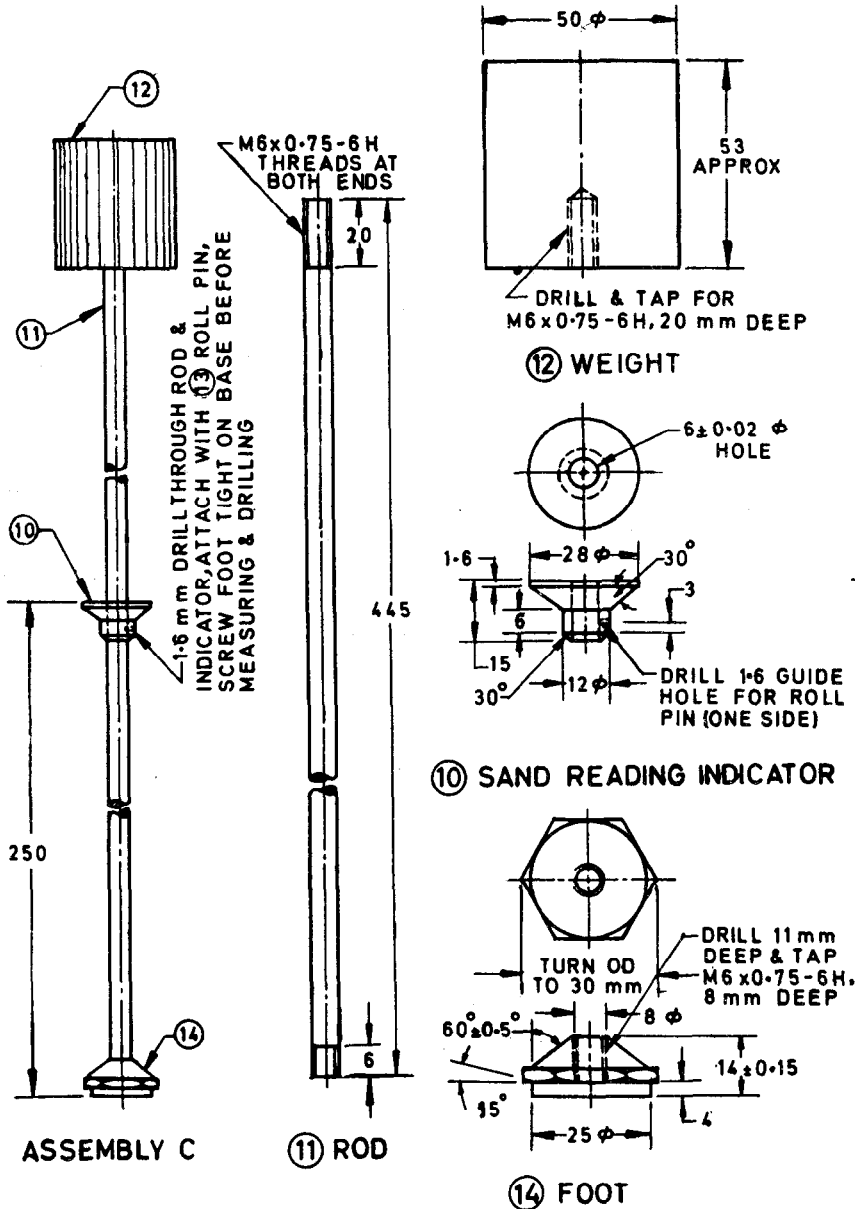

All dimensions in millimetres.

FIG. 1 SAND EQUIVALENT TEST APPARATUS—Contd

LIST OF MATERIALS

ASSEMBLY	PART NO.	DESCRIPTION	STOCK SIZE, mm	MATERIAL
A	<i>Siphon Assembly:</i>			
	1	Siphon tube	5 diameter, 410 length	Copper tube (may be plated)
	2	Siphon hose	3 ID, 1 220 length	Rubber tube, pure gum or equivalent
	3	Blow hose	3 ID, 50 length	Rubber tube, pure gum or equivalent
	4	Blow tube	5 diameter, 50 length	Copper tube (may be plated)
	5	2-hole stopper	To fit 4-litre bottle	Rubber
	6	Irrigator tube	6.4 OD wall, 500 length	Stainless steel tube
7	Clamp	A suitable pinchcock	—	
B	<i>Graduate Assembly:</i>			
	8	Tube	38 OD, 450 length	Transparent acrylic plastic
9	Base	12 × 100 × 100	Transparent acrylic plastic	
C	<i>Weighted Foot Assembly:</i>			
	10	Sand reading indicator	28 diameter, 15 height	Nylon
	11	Rod	6 diameter, 445 height	Brass (may be plated)
	12	Weight	50 diameter, 53 height	Cold rolled steel (may be plated)
	13	Roll pin	1.6 diameter, 12 height	Corrosion-resistant metal
	14	Foot	17.5 hex, 14 height	Brass (may be plated)
15	Solid stopper	To suit graduated cylinder	Rubber	
NOTE 1 — Assembly C — Weighted foot assembly should weigh 1 000 ± 5 g.				
NOTE 2 — Graduations on graduate to be in mm. Centimetre marks should be numerically designated.				
NOTE 3 — Accuracy of scale ± 0.02 mm.				

FIG.1 SAND EQUIVALENT TEST APPARATUS

3.11.2 Manually Operated — capable of producing an oscillating motion at a rate of 100 complete cycles in 45 ± 5 seconds, with a hand-assisted half stroke length of 125 ± 5 mm.

4. MATERIALS

4.1 Stock Calcium Chloride Solution — The materials listed below will be required:

- a) 480.4 g of technical grade anhydrous calcium chloride conforming to IS : 1314 - 1967*.
- b) 2 179 g of glycerine (technical grade) conforming to IS : 1796 -1961†.
- c) 49.7 g of formaldehyde (40 percent by volume solution) conforming to IS : 3321-1973‡.

4.1.1 Dissolve the 480.4 g of calcium chloride in 2 litres of distilled water. Cool and filter through ready pleated rapid filtering filter paper. Add 2 179 g of glycerine and the 49.7 g of formaldehyde to the filtered solution, mix well and dilute to 4 litres.

4.2 Working Calcium Chloride Solution — Prepare the working calcium chloride solution by diluting 90 ml of the stock calcium chloride solution to 4 litres with water. Use distilled or demineralized water for the normal preparation of the working solution. However, if it is determined that the local tap water is of such purity that it does not affect the test results, it is permissible to use it instead of distilled or demineralized water.

NOTE — The effect of local tap water on sand equivalent test results may be determined by comparing the results of three sand equivalent tests using distilled water with the results of three sand equivalent tests using the local tap water. The six test specimens required for this comparison shall be prepared from the same sample of material and oven-dried as prescribed in this method.

5. SAMPLE PREPARATION

5.1 Obtain at least 1 500 g of material passing 4.75-mm IS Sieve in the following manner.

5.1.1 Separate the sample on the 4.75-mm IS Sieve by means of a lateral and vertical motion of the sieve, accompanied by a jarring action so as to keep the sample moving continuously over the surface of the sieve. Continue the sieving until not more than one percent by mass of the residue passes the sieve during one minute. The sieving operation may be performed either by hand or by a mechanical apparatus. When thoroughness of mechanical sieving is being determined, test by the hand method described above using a single layer of material on the sieve.

*Specification for calcium chloride.

†Specification for crude glycerine and refined glycerine.

‡Specification for formaldehyde solution.

IS : 2720 (Part XXXVII) - 1976

5.1.2 Breakdown any lumps of material in the coarse fraction to pass the 4.75-mm IS Sieve. A mortar and rubber-covered pestle or any other means that will not cause appreciable degradation of the aggregate may be used.

5.1.3 Remove any coatings of fines adhering to the coarse aggregate. These fines may be removed by surface-drying the coarse aggregate, then rubbing between the hands over a flat pan.

5.1.4 Add the material passing the sieve as obtained in **5.1.2** and **5.1.3** to the separated fine portion of the sample.

5.2 Prepare test specimens from the material passing 4.75-mm IS Sieve portion of the sample by the procedure described in either **5.2.1** or **5.2.2**.

NOTE — Experiments show that as the amount of material being reduced by splitting or quartering is decreased, the accuracy of providing representative portions is decreased. For this reason, it is imperative that extreme care be exercised when preparing the test specimens.

5.2.1 Split or quarter enough material to fill four can measures to the brim or slightly rounded above the brim in the following manner.

5.2.1.1 If it appears necessary, dampen the material to avoid segregation or loss of fines during the splitting or quartering operations. Use care in adding water to the sample to retain a free-flowing condition of the material.

5.2.1.2 Using the measuring can, dip out four of these measures from the sample. Each time a measure full of the material is dipped from the sample, tap the bottom edge of the measure on a work table or other hard surface at least four times and jog it slightly to produce a measure of consolidated material level-full or slightly rounded above the brim.

5.2.1.3 Determine and record the amount of material contained in these four measures either by mass or by volume in a dry plastic cylinder.

5.2.1.4 Return this material back to the sample and proceed to split or quarter the material making the necessary adjustments to obtain this predetermined mass or volume. When this mass or volume is obtained, two successive splitting or quartering operations without adjustment should provide the proper amount of material to fill the measure.

5.2.1.5 Dry each test specimen to constant mass at $105 \pm 5^{\circ}\text{C}$ and cool to room temperature before testing.

NOTE — Sand equivalent results on test specimens that have not been dried will generally be lower than the results obtained on identical test specimens that have been dried. As a time-saving expedient, it is permissible to test most materials without drying when the sand equivalent value is used to determine compliance with a specification giving a minimum acceptable test value. If the resulting test value is lower than that specified, however, it will be necessary to rerun the test on a dried test specimen. If the sand equivalent, determined from a test on one dried test specimen, is below the minimum specification limit, it will be necessary to perform two additional tests on dried test specimens from the same sample. The sand equivalent for a sample shall be determined in accordance with **8**.

5.2.2 Prepare the desired number of test specimens from the sample as follows.

5.2.2.1 Maintaining a free-flowing condition, dampen the material sufficiently to prevent segregation or loss of fines.

5.2.2.2 Split or quarter out 1 000 to 1 500 g of the material. Mix thoroughly with a hand trowel in a circular pan by scopping toward the middle of the pan while rotating it horizontally. Mixing or remixing should be continued for at least 1 minute to achieve uniformity. Check the material for the necessary moisture condition by tightly squeezing a small portion of the thoroughly mixed sample in the palm of the hand. If a cast is formed that permits careful handling without breaking, the correct moisture range has been obtained. If the material is too dry, the cast will crumble and it will be necessary to add water and remix and retest until the material forms a cast. If the material shows any free water it is too wet to test and should be drained and air-dried, mixing it frequently to ensure uniformity. This overly wet material will form a good cast when checked initially, so the drying process should continue until a squeeze check on the drying material gives a cast which is more fragile and delicate to handle than the original. If the 'as received' water content is within the limits described above, the sample may be run immediately. If the water content is altered to meet these limits, the sample should be put in a pan, covered with a lid or with a damp trowel that does not touch the material, and allowed to stand for a minimum of 15 minutes.

5.2.2.3 After the minimum curing time, remix for 1 minute without water. When thoroughly mixed, form the material into a cone with a trowel.

5.2.2.4 Take the can measure in one hand and push it directly through the base of the pile while holding the free hand firmly against the pile opposite the measure.

5.2.2.5 As the can travels through the pile and emerges, apply enough hand pressure to cause the material to fill the can to overflowing. Press firmly with the palm of the hand, compacting the material until it consolidates in the can. The excess material should be struck off level with the top of the can, moving the edge of the trowel in a sawing motion across the brim.

5.2.2.6 To obtain additional test specimens, repeat the procedures in **5.2.2.3** to **5.2.2.5**.

6. PREPARATION OF APPARATUS

6.1 Fit the siphon assembly to a 4-litre bottle of working calcium chloride solution. Place the bottle on a shelf 915 ± 25 mm above the work surface.

NOTE — Instead of the 4-litre bottle, a glass or plastic vat having a larger capacity may be used provided the liquid level of the working solution is maintained between 915 and 115 mm above the work surface.

IS : 2720 (Part XXXVII) - 1976

6.2 Start the siphon by blowing into the top of the solution bottle through a short piece of tubing while the pinch clamp is open.

6.3 When using either the mechanical or the manually operated sand equivalent shaker, fasten the apparatus to a firm and level mount.

NOTE — If only a few sand equivalent tests are to be performed at one location, it is possible to hold the manually operated shaker by hand on a firm mount.

7. PROCEDURE

7.1 Siphon 100 ± 2 mm (indicated on the graduated cylinder) of working calcium chloride solution into the graduated cylinder.

7.2 Pour one of the test specimens into the graduated cylinder using the funnel to avoid spillage.

7.3 Tap the bottom of the cylinder sharply on the palm of the hand several times to release air bubbles and to promote thorough wetting of the specimen.

7.4 Allow the wetted specimen and cylinder to stand undisturbed for 10 ± 1 minutes.

7.5 At the end of the 10-minute soaking period, stopper the cylinder; then loosen the material from the bottom by partially inverting the cylinder and shaking it simultaneously.

7.6 After loosening the material from the bottom of the cylinder, shake the cylinder and contents by any one of the following three methods.

7.6.1 Mechanical Shaker Method — Place the stoppered cylinder in the mechanical sand equivalent shaker, set the time, and allow the machine to shake the cylinder and the contents for 45 ± 1 seconds.

7.6.2 Manual Shaker Method — Secure the stoppered cylinder to the shaker and shake for 100 strokes, with half stroke length of 125 ± 5 mm.

7.6.3 Hand Method

7.6.3.1 Hold the cylinder in a horizontal position and shake it vigorously in a horizontal linear motion from end to end.

7.6.3.2 Shake the cylinder 90 cycles in approximately 30 seconds using a throw of 230 ± 25 mm. A cycle is defined as a complete back and forth motion. To shake the cylinder at this speed properly, it will be necessary for the operator to shake with the forearms only, relaxing the body and shoulders.

7.7 Following the shaking operation, set the cylinder upright on the work table and remove the stopper.

7.8 Irrigation Procedure

7.8.1 During the irrigation procedure, keep the cylinder vertical and the base in contact with the work surface. Insert the irrigator tube in the top of the cylinder, remove the spring clamp from the hose, and rinse the material from the cylinder walls as the irrigator is lowered. Force the irrigator through the material to the bottom of the cylinder by applying a gentle stabbing and twisting action while the working solution flows from the irrigator tip. This flushes the fine material into suspension above the coarser sand particles.

7.8.2 Continue to apply a stabbing and twisting action while flushing the fines upward until the cylinder is filled to the 380 mm graduation. Then raise the irrigator tube slowly without shutting off the flow so that the liquid level is maintained at about the 380 mm graduation while the irrigator tube is being withdrawn. Regulate the flow just before the irrigator tube is entirely withdrawn and adjust the final level to the 380 mm graduation.

7.9 Allow the cylinder and contents to stand undisturbed for 20 minutes \pm 15 seconds. Start the timing immediately after withdrawing the irrigator tube.

7.10 At the end of the 20-minute sedimentation period, read and record the level of the top of the clay suspension as prescribed in **7.12**. This is referred to as the 'clay reading'. If no clear line of demarcation has formed at the end of the specified 20-minute sedimentation period, allow the sample to stand undisturbed until a clay reading can be obtained; then immediately read and record the level of the top of the clay suspension and the total sedimentation time. If the total sedimentation time exceeds 30 minutes, rerun the test using three individual specimens of the same material. Record the clay column height for the sample requiring the shortest sedimentation period as the clay reading.

7.11 Sand Reading Determination

7.11.1 After the clay reading has been taken, place the weighted foot assembly over the cylinder and gently lower the assembly until it comes to rest on the sand. Do not allow the indicator to hit the mouth of the cylinder as the assembly is being lowered.

7.11.2 As the weighted foot comes to rest on the sand, tip the assembly towards the graduations on the cylinder until the indicator touches the inside of the cylinder. Subtract 250 mm from the level indicated by the extreme top edge of the indicator and record this value as the 'sand reading'.

7.11.3 When taking the sand reading, take care not to press down on the weighted foot assembly since this could give an erroneous reading.

7.12 If clay or sand readings fall between 2-mm graduations, record the level of the higher graduation as the reading.

8. CALCULATIONS

8.1 Calculate the sand equivalent (*SE*) to the nearest 0.1 using the following formula:

$$SE = \frac{S_r}{C_r} \times 100$$

where

S_r = sand reading (see 7.11), and

C_r = clay reading (see 7.10).

8.2 When the result of this calculation is not a whole number, the sand equivalent (*SE*) shall be the next higher whole number.

Example:

$$SE = \frac{84}{204} \times 100 = 41.2 = 42$$

8.3 If it is desired to average a series of sand equivalent values, average the whole number values determined as described in 8.2.

Example: Calculated *SE* values 41.2, 43.8, 40.9 (see 8.1). After raising each to the next higher whole number they become 42, 44, 41 (see 8.2). Average of these values is

$$\frac{42+44+41}{3} = 42.3$$

Since the average value is not a whole number, the sand equivalent value is 43 (see 8.3).

9. PRECISION

9.1 Before an operator is allowed to perform the sand equivalent test, he should be capable of obtaining consistent test results on representative samples of any given material when the test is performed in accordance with the prescribed procedure for the particular method used. An operator's test results are considered to be consistent if the individual results of three tests performed by him on representative samples of the same material do not vary by more than ± 4 points from the average of these tests.

(Continued from page 2)

<i>Members</i>	<i>Representing</i>
DEPUTY DIRECTOR RESEARCH (SOIL MECHANICS)-I	Railway Board (Ministry of Railways)
ASSISTANT DIRECTOR RESEARCH (SOIL MECHANICS)-I (<i>Alternate</i>)	
SHRI R. L. DEWAN	Irrigation Research Institute, Khagaul, Patna
DIRECTOR (CSMRS)	Central Water Commission, New Delhi
DEPUTY DIRECTOR (CSMRS)	(<i>Alternate</i>)
SHRI H. K. GUHA	Geologists' Syndicate Pvt Ltd, Calcutta
SHRI N. N. BHATTACHARAYA	(<i>Alternate</i>)
DR SHASHI K. GULHATI	Indian Institute of Technology, New Delhi
SHRI R. K. JAIN	United Technical Consultants Pvt Ltd, New Delhi
DR P. K. DE (<i>Alternate</i>)	
SHRI O. P. MALHOTRA	Buildings & Roads Research Laboratory, Govern- ment of Punjab
DIRECTOR (<i>Alternate</i>)	
DR V. V. S. RAO	In personal capacity (<i>F-24 Green Park, New Delhi</i>)
SHRI H. C. VERMA	Associated Instrument Manufacturers (India) Pvt Ltd, New Delhi
PROF T. S. NAGARAJ (<i>Alternate</i>)	

**INDIAN STANDARDS
ON
METHODS OF TEST FOR SOILS**

IS: 2720 Methods of test for soils:

- (Part I)-1972 Preparation of dry soil samples for various tests (*first revision*)
- (Part II)-1973 Determination of water content (*second revision*)
- (Part III)-1964 Determination of specific gravity
- (Part IV)-1975 Grain size analysis (*first revision*)
- (Part V)-1970 Determination of liquid and plastic limits (*first revision*)
- (Part VI)-1972 Determination of shrinkage factors (*first revision*)
- (Part VII)-1974 Determination of water content-dry density relation using light compaction (*first revision*)
- (Part VIII)-1974 Determination of water content-dry density relation using heavy compaction (*first revision*)
- (Part IX)-1971 Determination of dry density-moisture content relation by constant weight of soil method
- (Part X)-1973 Determination of unconfined compressive strength (*first revision*)
- (Part XI)-1971 Determination of the shear strength parameters of a specimen tested in un-consolidated undrained triaxial compression without the measurement of pore water pressure
- (Part XII)-1975 Determination of shear strength parameters of soil from consolidated undrained triaxial test with measurement of pore water pressure
- (Part XIII)-1972 Direct shear test (*first revision*)
- (Part XIV)-1968 Determination of density index (relative density) of cohesionless soils
- (Part XV)-1965 Determination of consolidation properties
- (Part XVI)-1965 Laboratory determination of CBR
- (Part XVII)-1966 Laboratory determination permeability
- (Part XVIII)-1964 Determination of field moisture equivalent
- (Part XIX)-1964 Determination of centrifuge moisture equivalent
- (Part XX)-1966 Determination of linear shrinkage
- (Part XXI)-1965 Determination of total soluble solids
- (Part XXII)-1972 Determination of organic matter (*first revision*)
- (Part XXIII)-1976 Determination of calcium carbonate (*first revision*)
- (Part XXIV)-1976 Determination of cation exchange capacity (*first revision*)
- (Part XXV)-1967 Determination of silica sesquioxide ratio
- (Part XXVI)-1973 Determination of pH value (*first revision*)
- (Part XXVII)-1968 Determination of total soluble sulphates
- (Part XXVIII)-1974 Determination of dry density of soils, in-place by the sand replacement method (*first revision*)
- (Part XXIX)-1975 Determination of dry density of soils, in-place by the core-cutter method (*first revision*)
- (Part XXX)-1968 Laboratory vane shear test
- (Part XXXI)-1969 Field determination of California bearing ratio
- (Part XXXII)-1970 North dakota cone test
- (Part XXXIII)-1971 Determination of the density in-place, by the ring and water replacement method
- (Part XXXIV)-1972 Determination of density of soil in-place, by rubber-balloon method
- (Part XXXV)-1974 Measurement of negative pore water pressure
- (Part XXXVI)-1975 Laboratory determination of permeability of granular soil (constant head)
- (Part XXXVII)-1976 Determination of sand equivalent value of soils and fine aggregates
- (Part XXXVIII)-1976 Compaction control test (Hilf method)



INDIAN STANDARDS INSTITUTION

Headquarters :

Manak Bhavan, 9 Bahadur Shah Zafar Marg, NEW DELHI 110002

Telephones : 3 31 01 31, 3 31 13 75

Telegrams : Manaksanstha
(Common to all Offices)

Regional Offices :

Telephone

*Western : Manakalaya, E9 MIDC, Marol, Andheri (East), 6 32 92 95
BOMBAY 400093

†Eastern : 1/14 C. I. T. Scheme VII M, V. I. P. Road, 36 24 99
Maniktola, CALCUTTA 700054

Northern : SCO 445-446, Sector 35-C { 2 18 43
CHANDIGARH 160036 { 3 16 41

Southern : C. I. T. Campus, MADRAS 600113 { 41 24 42
{ 41 25 19
{ 41 29 16

Branch Offices :

Pushpak, Nurmohamed Shaikh Marg, Khanpur, { 2 63 48
AHMADABAD 380001 { 2 63 49

'F' Block, Unity Bldg, Narasimharaja Square, 22 48 05
BANGALORE 560002

Gangotri Complex, 5th Floor, Bhadbhada Road, T. T. Nagar, 6 27 16
BHOPAL 462003

Plot No. 82/83, Lewis Road, BHUBANESHWAR 751002 5 36 27

53/5 Ward No. 29, R. G. Barua Road, —
5th Byelane, GUWAHATI 781003

5-8-56C L. N. Gupta Marg, (Nampally Station Road), 22 10 83
HYDERABAD 500001

R14 Yudhister Marg, C Scheme, JAIPUR 302005 { 6 34 71
{ 6 98 32

117/418B Sarvodaya Nagar, KANPUR 208005 { 21 68 76
{ 21 82 92

Patliputra Industrial Estate, PATNA 800013 6 23 05

Hantex Bldg (2nd Floor), Rly Station Road, 52 27
TRIVANDRUM 695001

Inspection Office (With Sale Point):

Institution of Engineers (India) Building, 1332 Shivaji Nagar, 5 24 35
PUNE 410005

*Sales Office in Bombay is at Novelty Chambers, Grant Road, 89 65 28
Bombay 400007

†Sales Office in Calcutta is at 5 Chowringhee Approach, P. O. Princep 27 68 00
Street, Calcutta 700072