

IS : 2720 (Part 36) - 1987

Indian Standard

METHODS OF TEST FOR SOILS

PART 36 LABORATORY DETERMINATION OF PERMEABILITY OF
GRANULAR OF SOIL (CONSTANT HEAD)

(First Revision)

UDC 624.131.37 : 624.131.433

© Copyright 1988

BUREAU OF INDIAN STANDARDS
MANAK BHAVAN, 9 BAHADUR SHAH ZAFAR MARG
NEW DELHI 110002

Indian Standard

METHODS OF TEST FOR SOILS

PART 36 LABORATORY DETERMINATION OF PERMEABILITY OF GRANULAR OF SOIL (CONSTANT HEAD)

(*First Revision*)

0. FOREWORD

0.1 This Indian Standard (Part 36) (First Revision) was adopted by the Bureau of Indian Standards on 29 October 1987, after the draft finalized by the Soil Engineering Sectional Committee had been approved by the Civil Engineering Division Council.

0.2 With a view to establish uniform procedures for determination of different characteristics of soils and also for facilitating comparative studies of the results, an Indian Standard on methods of test for soils (IS : 2720) is being published in various parts. This part describes the method for determination of coefficient of permeability of granular soils by a constant head method and under conditions of laminar flow of water. The knowledge of this property is essential in a solution of problems involving de-watering, yield of water bearing strata, seepage through earth dams, etc. A reliable determination of permeability can be made only when the conditions for the validity of Darcy Law are

fulfilled, that is, when the flow is steady and laminar and the soil is saturated and the rate of flow is proportional to the hydraulic gradient. Part 17 of this standard covers the general method but this part covers the disturbed granular materials containing less than 10 percent soil passing through 75 micron IS sieve which are used in embankments, earth dams base courses, etc and thus has different test apparatus. This standard was first published in 1975. Based on the experience gained in conducting this test in the past 13 years, the procedures have been updated and figures have been modified. The opportunity has also been taken to make references of latest Indian Standards which have been published or revised in this period.

0.3 In reporting the result of a test or analysis made in accordance with this standard, if the final value, observed or calculated, is to be rounded off, it shall be done in accordance with IS : 2-1960*.

*Rules for rounding off numerical values (*revised*).

1. SCOPE

1.1 This standard (Part 36) describes the method for determining coefficient of permeability of granular soils by a constant head method and under conditions of laminar flow of water. This method is suitable for disturbed granular soil containing less than 10 percent soil passing 75-micron IS Sieve, the type of material used for construction of embankments and base courses under pavements.

1.1.1 Prerequisite for laminar flow of water through granular soils is that, water shall flow below critical velocity so that there is no movement or disturbance of soil particles; moreover, water shall flow through saturated soil voids without having bubbles in them, and there shall be no change in soil volume nor any change in hydraulic gradient during the performance of the test.

2. EQUIPMENT

2.1 Permeameter — As shown in Fig. 1, the permeameter shall have specimen cylinders with minimum diameters approximately 8 or 12 times the maximum particle size in accordance with

Table 1. The permeameter shall be fitted with:

- a) A porous disc or suitable reinforced screen at the bottom with a permeability greater than that of the soil specimen, but with openings sufficiently small (not larger than 10 percent of finer size of the soil to be tested) to prevent the movement of particles;
- b) Manometer outlets for measuring the loss of head, h , over a length, L , equivalent to at least the diameter of the cylinder; and
- c) A porous disc or suitable reinforced screen with spring attached to the top, or any other device for applying a light spring pressure of 2 to 4 kg total load when the top plate is attached in place. This will hold the placement density and volume of soil without significant change during the saturation of the specimen and the permeability testing to satisfy the requirement that there should be no soil volume change during a test.

NOTE -- Perforated metal disc may also be used for the test.

TABLE 1 CYLINDER DIAMETER

(Clauses 2.1 and 4.1)

MAXIMUM PARTICLE SIZE BETWEEN IS SIEVE OPENINGS (mm)	MINIMUM CYLINDER DIAMETER (mm)			
	Not More than 35 per cent of Total Soil Retained on Sieve Opening		More than 35 per cent of Total Soil Retained on Sieve Opening	
	2.00 mm	10.00 mm	2.00 mm	10.00 mm
(1)	(2)	(3)	(4)	(5)
2.00 and 10.00	80	—	120	—
10.00 and 20.00	—	160	—	230

NOTE — The diameter to length ratio may be about 1 : 2.

2.2 Constant-Head Filter Tank — This shall be as shown in Fig. 1, to supply water and shall be

fitted with suitable control valves to prevent formation of air bubbles in the soil voids. The size of the constant head filter tank shall be large enough to meet the demand depending upon the permeability of the specimen.

NOTE — There are several methods of reducing air content of water, such as (a) by boiling, (b) by spraying water into a partial vacuum, (c) to use water having higher temperature, at least 5°C more than that of the soil specimen under test, and (d) by running water before use through a porous fine grained material so that the air is entrapped in the interstices of the material. Out of all these methods of deairing water, the last method of passing tap water through filter is less expensive and more suitable, specially when large quantities of deaired water are required to be used. It will be essential that the filter material should be of finer grade than that of the soil to be tested otherwise air may come out of the solution in water while passing through the soil mass. But still if preferred, the deaired water prepared by boiling or spraying through partial vacuum may be used.

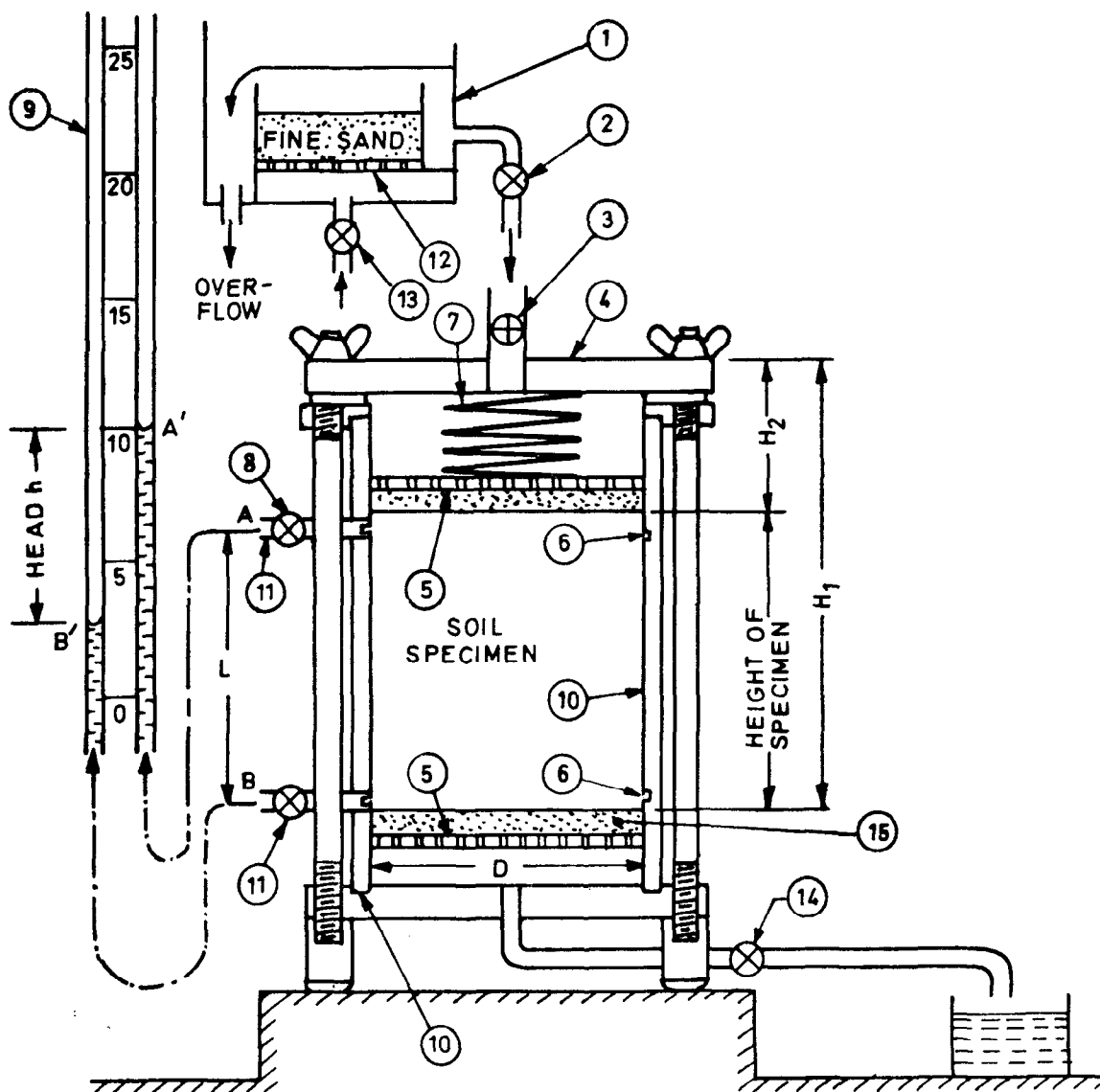

- 1) Constant-head filter tank (NTC)
- 2) Filter tank valve
- 3) Inlet valve
- 4) Top plate
- 5) Porous disc or screen
- 6) Screened manometer groove
- 7) Spring
- 8) Manometer valve
- 9) Manometer tubes
- 10) Metal or transparent acrylic plastic cylinder
- 11) Manometer outlet
- 12) Screen
- 13) Tap water valve
- 14) Outlet valve
- 15) Gravel filter

FIG. 1 CONSTANT HEAD PERMEAMETER

2.3 Large Funnels — These shall be fitted with special cylindrical spout, 25 mm in diameter for 10.00 mm maximum size particles, and 13 mm in diameter for 2.00 mm maximum size particles. The length of the spout should be greater than the full length of the permeability chamber at least by 160 mm.

2.4 Specimen Compaction Equipment — Compaction equipment as deemed desirable may be used. The following are suggested:

- a) A vibrating tamper fitted with a tamping foot 50 mm in diameter;
- b) A sliding tamper with a tamping foot 50 mm in diameter and a rod for sliding weights of 100 g (for sands) to 1 kg (for soils with a large gravel content), having an adjustable height of drop to 100 mm for sands and 200 mm for soils with large gravel contents.

2.5 Vacuum Pump or Water Faucet Aspirator — for evacuating and for saturating soil specimen under full vacuum (see Fig. 2).

2.6 Balance — It shall be of 2 kg capacity and sensitive to 1 g.

2.7 Scoop — with a capacity of 100 g of soil.

2.8 Miscellaneous Apparatus — Thermometers, clock with sweep second hand, 250 ml graduated cylinder and mixing pan.

3. SAMPLE

3.1 A representative sample of air-dried granular soil containing less than 10 percent of the material

passing 75-micron IS Sieve and equal to an amount sufficient to satisfy the requirements prescribed in 3.2 and 3.3 shall be selected by the method of quartering.

3.2 A sieve analysis [in accordance with IS : 2720 (Part 4)-1986*] shall be made on a representative sample of the complete soil prior to the permeability test. All particles larger than 20 mm IS Sieve shall be separated out by sieving. This oversize material shall not be used for the permeability test but the percentage of the oversize material shall be recorded. The grading analysis data thus obtained shall also be utilized for determining the required grading for sand or gravel filter to be used at the bottom and top of the compacted sample in the permeameter. From the grading curve, the particle sizes corresponding to 85 percent and 15 percent points shall be noted and the filter designed accordingly.

NOTE -- In order to establish representative values of coefficient of permeabilities for the range which may exist in the soil at site being investigated, samples of the finer, average and coarser soils should be obtained for testing.

3.3 From the material, from which the oversize has been removed (see 3.2), select by the method of quartering a sample for testing equal to an amount approximately twice that required for filling the permeameter chamber.

4. PREPARATION OF SPECIMEN

4.1 The size of permeameter to be used shall be as prescribed in Table 1.

*Methods of test for soils: Part 4 Grain size analysis (second revision).

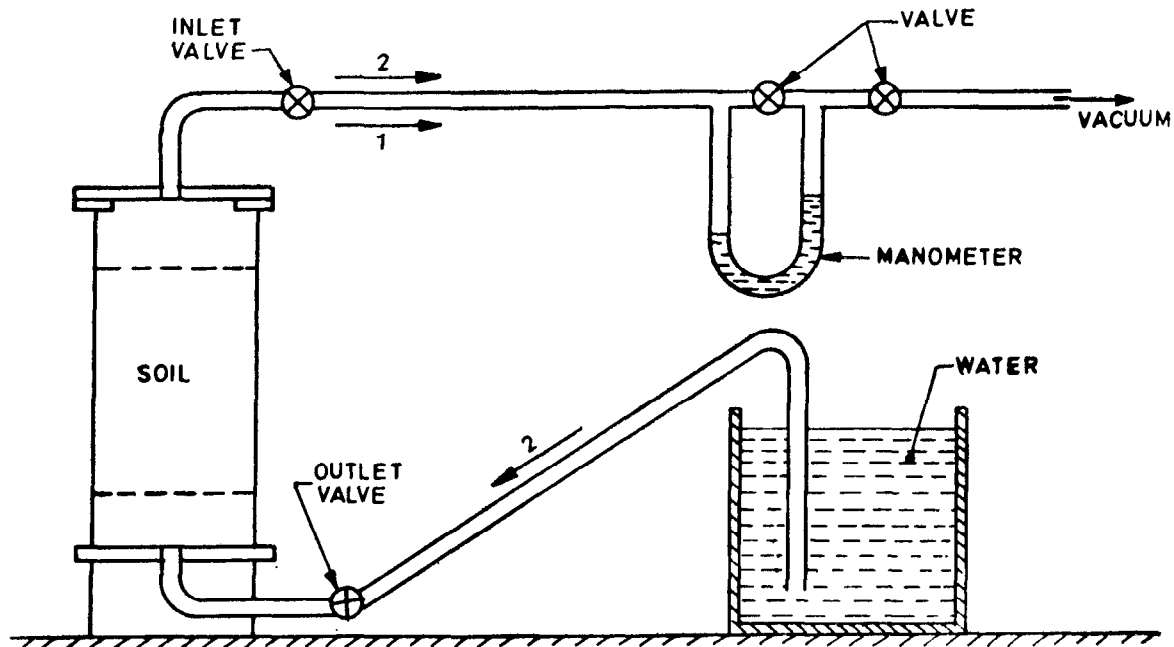

FIG. 2 DEVICE FOR EVACUATING AND SATURATING SPECIMEN

4.2 Make the following initial measurements and record on the data sheet (Appendix A), the inside diameter, D , of the permeameter; the length, L , between the manometer outlets; and the depth, H_1 , measured at four symmetrically spaced points from the upper surface of the top plate of the permeability cylinder to the top of the upper porous stone or screen temporarily placed on the lower porous plate or screen. This automatically deducts the thickness of the upper porous plate or screen from the height measurements used to determine the volume of soil placed in the permeability cylinder. A duplicate top plate containing four large symmetrically spaced openings through which the necessary measurements can be made, shall be employed to determine the average value for H_1 . Calculate the cross-sectional area A of the specimen.

4.3 A small portion of the sample selected as prescribed in 3.2 and 3.3 shall be taken for water content determinations. Record the weight of the remaining air-dried sample (see 3.3), W_1 , for unit weight determinations.

4.4 Place the prepared soil by one of the following procedures in uniform thin layers approximately 15 to 20 mm.

NOTE — In case of granular soils there is every likelihood that water would separate through between the specimen and the wall of the cylinder. In order to prevent this, special precautions are suggested to be observed. For fine sands, a water-pump grease should be applied to the cylinder wall to prevent flow of water between the specimen and the wall. For coarse sand, a 7-mm thickness of sponge rubber cemented to the cylinder wall is found to be satisfactory.

4.4.1 For soils having a maximum size of 10 mm or less, place the appropriate size of funnel, as prescribed in 2.3, in the permeability device with the spout in contact with the lower porous plate or screen or previously formed layer, and fill the funnel with sufficient soil to form a layer, taking soil from different areas of the sample in the pan. Lift the funnel by 15 mm or approximately the unconsolidated layer thickness to be formed, and spread the soil with a slow spiral motion, working from the perimeter of the device towards the centre, so that a uniform layer is formed. Remix the soil in the pan for each successive layer to reduce segregation caused by taking soil from the pan.

4.4.2 For soils with a maximum size greater than 10.00 mm, spread the soil from a scoop. Uniform spreading can be obtained by sliding a scoopful of soil in a nearly horizontal position down along the inside surface of the device to the bottom or to the formed layer, then tilting the scoop and drawing it towards the centre with a single slow motion, this allows the soil to run smoothly from the scoop in a windrow without segregation. Turn the permeability cylinder sufficiently for the next scoopful, thus progressing around the inside perimeter to form a uniform compacted layer of a thickness equal to the maximum particle size.

4.5 Compact successive layers of soil to the desired relative density by appropriate procedure, as follows, to a height of about 20-mm above the upper manometer outlet.

4.5.1 *Minimum Density (Zero Percent Relative Density)* — Continue placing layers of soil in succession by one of the procedures described in 4.4.1 until the device is filled to the proper level.

4.5.2 *Maximum Density (100 Percent Relative Density)*

4.5.2.1 *Compaction by vibrating tamper* — Compact each layer of soil thoroughly with the vibrating tamper, distributing the light tamping action uniformly over the surface of the layer in a regular pattern. The pressure of contact and the length of time of the vibrating action at each spot should not cause soil to escape from beneath the edges of the tamping foot, thus tending to loosen the layer. Make a sufficient number of coverages to produce maximum density, as evidenced by practically no visible motion of surface particles adjacent to the edges of the tamping foot.

4.5.2.2 *Compaction by sliding weight tamper* — Compact each layer of soil thoroughly by tamping blows uniformly distributed over the surface of the layer. Adjust the height of drop and give sufficient coverages to produce maximum density, depending on the coarseness and gravel content of the soil.

4.5.2.3 *Compaction by other methods* — Compaction may be accomplished by other approved methods, such as deposition under water, by vibratory packer equipment where care is taken to obtain a uniform specimen without segregation of particle sizes.

4.5.3 *Relative Density Intermediate Between Zero and 100 Percent* — By trial in a separate container of the same diameter as the permeability cylinder, adjust the compaction to obtain reproducible values of relative density. Compact the soil in the permeability cylinder by these procedures in thin layers to a height of about 20 mm above the upper manometer outlet.

NOTE — In order to cover systematically and representatively, the relative density conditions that may govern in natural deposits or in compacted embankments, a series of permeability tests should be made to cover the range of field relative densities.

4.6 Preparation of Specimen for Permeability Test

4.6.1 Level the upper surface of the soil by placing the upper porous plate or screen in position and by rotating it gently clockwise and anti-clockwise.

4.6.2 Measure and record the final height of specimen, H_1-H_2 , by measuring the depth, H_2 , from the upper surface of the perforated top plate employed to measure H_1 to the top of the upper porous plate or screen at four symmetrically spaced points after compressing the spring lightly to seat

the porous plate or screen during the measurements; the final weight of air-dried soil used in the test ($W_1 - W_2$) by weighing the remainder of soil W_2 left in the pan. Compute and record the unit weights, void ratio, and relative density of the test specimen.

4.6.3 With its gasket in place, press down the top plate against the spring and attach it securely to the top of the permeameter cylinder, making an airtight seal. This satisfies the condition of no volume change during testing for holding the initial density.

4.6.4 Connect the inlet tube of the top plate of the permeameter to a vacuum pump or suitable aspirator capable of evacuating the air content from the specimen and the outlet tube in the base plate to the water container as shown in Fig. 2. Close the manometer outlets [see 2.1 (b)] and the outlet valve at the base plate of the permeameter. Using a vacuum pump or aspirator, evacuate the specimen under 500 mmHg, minimum for 15 minutes to remove air adhering to soil particles and from the voids. Follow the evacuation by a slow saturation of the specimen from the bottom upward under full vacuum in order to force any remaining air in the specimen. Continued saturation of the specimen can be maintained more adequately by the use of deaired water, or water maintained at an in-flow temperature sufficiently high to cause a decreasing temperature gradient in the specimen during the test. Native water or water of low mineral content (see Note) should be used for the test, but in any case the fluid should be described on the report form (Appendix A). This satisfies the conditions of laminar flow through saturated soil voids.

NOTE — Native water is water occurring in the rock or soil *in-situ*. It should be used if possible, but it (as well as deaired water) may need a refinement not ordinarily feasible for large scale production testing in which case available water may be used and so stated in the report.

4.6.5 After the specimen has been saturated and the permeameter is full of water, close the bottom valve on the outlet tube (see Fig. 2) and disconnect the vacuum. Care should be taken to ensure that the permeability flow system and the manometer system are free of air and are working satisfactorily. Fill the inlet tube with water from the constant-head tank by slightly opening the filter tank valve. Then connect the inlet tube to the top of the permeameter, open the inlet valve slightly and open the manometer outlet cocks slightly, to allow water to flow, thus freeing them of air. Connect the water manometer tubes to the manometer outlets and fill with water to remove the air. Close the inlet valve and open the outlet valve to allow the water in the manometer tubes to reach their stable water level under zero head.

5. PROCEDURE

5.1 Open the inlet valve from the filter tank slightly for the first run, delay measurements of quantity of flow and head until a stable head condition without appreciable drift in water manometer level is attained. Measure and record the time t , head h (the difference in level in the manometers), quantity of

of flow Q , and water temperature T .

5.2 Repeat the test runs at heads, increasing by 5 mm in order to establish accurately the region of laminar flow with velocity v (where $v = Q/At$), directly proportional to hydraulic gradient i (where $i = h/L$). When departures from the linear relation become apparent, indicating the initiation of turbulent flow conditions, 10 mm intervals of head may be used to carry the test run sufficiently along in the region of turbulent flow to define this region if it is significant for field conditions.

NOTE — Much lower values of hydraulic gradient h/L are required than generally recognized, in order to ensure laminar flow conditions. The following values are suggested: loose compactness ratings h/L from 0.2 to 0.3; and dense compactness ratings h/L from 0.3 to 0.5; the lower values of h/L apply to coarser soils and the higher values to finer soils.

5.3 At the completion of the permeability test, drain the specimen and inspect it to establish whether it was essentially homogenous and isotropic in character. Any light and dark alternating horizontal streaks or layers are evidence of segregation of fines.

6. RECORD OF OBSERVATION

6.1 The inside diameter D of the permeameter, the length L between manometer outlets and depth H_1 (Fig. 1) are measured and recorded in Appendix A. For the given soil, water content is determined and recorded. The weight W_s , of air dried soil used in preparing soil specimen is also recorded. The final height of specimen after compression by spring, $H_1 - H_2$, is measured and recorded. Dry unit weight and void ratio are calculated. The temperature of water, T is measured and recorded.

6.2 During the test, observations are made of manometer readings h_1 and h_2 , quantity of flow Q collected in a graduated jar in the time t and are recorded in columns (2) to (5) respectively. Head h (= $h_1 - h_2$) is calculated to column (6) and gradient i (= h/L) is calculated and recorded in column (7). Finally, permeability k_T is calculated and recorded in column (8). Remarks, if any, are entered in column (9).

7. CALCULATIONS

7.1 Permeability k_T at temperature T is calculated by:

$$k_T = \frac{Q}{A i t}$$

and permeability at 27°C by using the expression

$$k_{27} = k_T \frac{\mu_T}{\mu_{27}}$$

where

μ_T = Coefficient of viscosity at $T^\circ\text{C}$, and

μ_{27} = Coefficient of viscosity at 27°C.

Void ratio e is calculated as

$$e = \frac{G_s \gamma_w}{\gamma} - 1$$

in which γ_w is the density of water and is taken as 1 g/cm^3 , γ is dry unit weight of specimen and G_s is the specific gravity.

7.2 A data sheet with observation data, calculation and result is presented in Appendix A.

8. PRESENTATION OF RESULTS

8.1 The values of permeability, calculated at T and 27°C are reported as numbers with units of cm/sec . Also reported are the dry density and void ratio of the sample.

APPENDIX A

(Clauses 4.2, 4.6.4, 6.1 and 7.2)

Project _____ Test No. _____
 Sample No. _____ Date _____
 Soil identification _____ Tested by _____
 Diameter of specimen, D _____ cm
 Spacing between manometer outlets, $L =$ _____ cm
 Length of specimen ($H_1 - H_2$) = _____ - _____ = _____ cm
 Area of specimen, $A = \frac{\pi D^2}{4} =$ _____ cm^2
 Volume of specimen, $V = A (H_1 - H_2) =$ _____ cm^3
 Water content, $W =$ _____ %
 Dry weight of soil specimen, $W_s =$ _____ g
 Dry unit weight $\gamma = \frac{W_s}{V} =$ _____ g/cm^3
 Specific gravity, $G_s =$ _____ Void ratio, $e = \frac{G_s \gamma_w}{\gamma} - 1 =$ _____
 Temperature of water $T =$ _____ $^\circ\text{C}$

SL No.	MANOMETER READINGS		QUANTITY OF FLOW, Q	TIME, t SECONDS	HEAD $h = h_1 - h_2$	$i = h/L$	$k_D = \frac{Q}{A i t}$	REMARKS
	h_1	h_2						
(1)	(2)	(3)	(4)	(5)	(6)	(7)	(8)	(9)
	cm	cm	cm^3		cm			

$$k_{27} = k_T \frac{\mu_T}{\mu_{27}} = \text{_____ cm/sec}$$

BUREAU OF INDIAN STANDARDS

Headquarters:

Manak Bhavan, 9 Bahadur Shah Zafar Marg, NEW DELHI 110002

Telephones : 331 01 31 331 13 75

Telegrams : Manaksanstha
(Common to all Offices)

Regional Offices:

	Telephone
Central : Manak Bhavan, 9 Bahadur Shah Zafar Marg, NEW DELHI 110002.	331 01 31, 331 13 75
*Eastern : 1/14 C. I. T. Scheme VII M, V. I. P. Road, Maniktola, CALCUTTA 700054	36 24 99
Northern : SCO 445-446, Sector 35-C, CHANDIGARH 160036	2 18 43, 3 16 41
Southern : C. I. T. Campus, MADRAS 600113	41 24 42, 41 25 19, 41 29 16
†Western : Manakalaya, E9 MIDC, Marol, Andheri (East), BOMBAY 400093	6 32 92 95

Branch Offices:

‘Pushpak’, Nurmohamed Shaikh Marg, Khanpur, AHMADABAD 380001	2 63 48, 2 63 49
Peenya Industrial Area, 1st Stage, Bangalote Tumkur Road, BANGALORE 560058	38 49 55, 38 49 56
Gangotri Complex, 5th Floor, Bhadbhada Road, T. T. Nagar, BHOPAL 462003	6 67 16
Plot No. 82/83, Lewis Road, BHUBANESHWAR 751002	5 36 27
53/5 Ward No. 29, R. G. Barua Road, 5th By-lane, GUWAHATI 781003	—
5-8-56C L. N. Gupta Marg (Nampally Station Road), HYDERABAD 500001	23 10 83
R14 Yudhister Marg, C Scheme, JAIPUR 302005	6 34 71, 6 98 32
117/418 B Sarvodaya Nagar, KANPUR 208005	21 68 76, 21 82 92
Patliputra Industrial Estate, PATNA 800013	6 23 05
T.C. No. 14/1421, University P.O. Palayam, TRIVANDRUM 695035	7 66 37

Inspection Offices (With Sale Point):

Pushpanjali, First Floor, 205-A West High Court Road, Shankar Nagar Square, NAGPUR 440010	2 51 71
Institution of Engineers (India) Building, 1332 Shivaji Nagar, PUNE 411005	5 24 35

*Sales Office in Calcutta is at 5 Chowringhee Approach,
P.O. Princep Street, CALCUTTA 700072

27 68 00

†Sales Office in Bombay is at Novelty Chambers, Grant Road
BOMBAY 400007

89 65 28