

भारतीय मानक  
मृदा परीक्षण पद्धतियाँ  
भाग 31 कैलिफोर्निया धारण अनुपात  
( पहला पुनरीक्षण )

*Indian Standard*

**METHODS OF TEST FOR SOILS**

**PART 31 FIELD DETERMINATION OF CALIFORNIA BEARING RATIO**

*( First Revision )*

UDC 624.131.383

© BIS 1991

**BUREAU OF INDIAN STANDARDS**  
MANAK BHAVAN, 9 BAHADUR SHAH ZAFAR MARG  
NEW DELHI 110002

## FOREWORD

This Indian Standard ( Part 31 ) ( First Revision ) was adopted by the Bureau of Indian Standards, after the draft finalized by the Soil and Soil Engineering Sectional Committee had been approved by the Civil Engineering Division Council.

The bearing ratio test ( generally known as the California bearing ratio test ) is an *ad hoc* penetration test used for the evaluation of the strengths of sub-grade and bases for roads and runway pavements. The results obtained from these tests are used in conjunction with the empirical curves, based on experience for the design of flexible pavements. The test gives empirical strength values which may not be directly related to fundamental properties governing the strength of soil. The test is either performed in the laboratory [ see IS : 2720 ( Part 11 ) : 1971 ] or directly in the field. The test may also be performed in the laboratory on undisturbed sample or sample re-compacted to the field density. The laboratory procedure has been covered in IS 27.0 ( Part 16 ) : 1987.

This standard covers the method of test to be conducted in the field. This standard was first published in 1969. The principal modifications made in the revision are:

- a) Revising the method of procedure based on the experience gained in the use of this test in the past 20 years;
- b) Incorporating the references of various Indian Standards some of which have been revised and some of them have been brought out as new standard; and
- c) Incorporating SI units in place of metric units.

# *Indian Standard*

## METHODS OF TEST FOR SOILS

### PART 31 FIELD DETERMINATION OF CALIFORNIA BEARING RATIO

#### ( *First Revision* )

#### 1 SCOPE

1.1 This Indian Standard ( Part 31 ) ( First Revision ) covers the method for the determination of the bearing ratio ( generally known as the California bearing ratio ) of soils in place for the evaluation of strengths of sub-grade and bases for roads and runaway pavements.

#### 2 REFERENCES

2.1 The Indian Standards as given in Annex A are necessary adjuncts to this standard.

#### 3 TERMINOLOGY

3.0 For the purpose of this standard, the definitions given in IS 2809 : 1972 and the following definitions shall apply.

#### 3.1 Bearing Ratio ( Generally known as California Bearing Ratio or CBR )

The ratio of the force per unit area required to penetrate a soil mass with a standard circular piston at the rate of 1.25 mm/min to that required for corresponding penetration of a standard material.

#### 3.2 Standard Load

Load which has been obtained from the test on crushed stone which is defined as having a bearing ratio of 100 percent ( *see* 6.2 ).

#### 4 APPARATUS

##### 4.1 Loading Device

A mechanical screw loading jack with swivel head for applying load to the penetration piston. The device should have an arrangement for attachment to truck, tractor, truss or any other equipment used to provide load reaction. The jack should be such that a uniform penetration rate of 1.25 mm/min can be achieved. The capacity of the jack should not be less than 50 kN.

##### 4.2 Equipment for Providing Reaction for Loading

Truck, tractor, truss or any other suitable equipment. If truck or tractor, is used they should be loaded suitably to give the necessary reaction. If truss is used it should be suitably anchored.

##### 4.3 Jacks

Two track-type jacks of 50 to 120 kN capacity, having double acting combination trip and automatic lowering in cases where loaded truck or tractor is used for providing the necessary reaction.

##### 4.4 Proving Ring

One calibrated proving ring of suitable capacity having an accuracy of not more than one percent of the anticipated load shall be used. The calibration of the proving ring shall be checked periodically at least once a year.

##### 4.5 Metal Penetration Piston

50 ± 0.1 mm in diameter and not less than 100 mm long.

##### 4.6 Extensions

Internally threaded pipe or rod extensions not less than 200 cm long furnished in the following quantities and lengths:

<i>Length of Extension</i> ( <i>see Note</i> ) cm	<i>Number of</i> <i>Extensions</i>
5	2
10	2
30	1
50	1
100	1

NOTE — Other convenient lengths may also be used.

##### 4.7 Connectors

For coupling the penetration piston and proving ring assembly either directly or through extension pieces.

##### 4.8 Dial Gauge

Reading to 0.01 mm having a travel of 25 mm, for measuring the penetration of the piston.

##### 4.9 Dial Gauge Support

Rigid and of steel, angle welded construction or light alloy pipe construction about 2 m long, of overall height 30 cm and 45 cm wide at the feet with universal or ordinary dial gauge holder adjustable anywhere along the length of the support.

#### 4.10 Surcharge Weight

One annular metal weight of mass 5 kg and of 250 mm diameter with a central hole 53 mm in diameter. Two circular slotted weights of mass 5 kg and of diameter 215 to 250 mm with a central hole and slot width of 53 mm. Two circular slotted weights of mass 10 kg and of diameter 215 to 250 mm with a central hole and slot width of 53 mm.

#### 4.11 Miscellaneous Apparatus

Other general apparatus, such as spirit level, pick, spade, scoop and brush, apparatus for moisture determination [ see IS 2720 ( Part 2 ) : 1973 ] and density determination [ see IS 2720 ( Part 28 ) : 1974 and IS 2720 ( Part 29 ) : 1975 ].

### 5 PROCEDURE

**5.1** The general surface area to be tested should be exposed, cleaned of all loose and dried material and levelled. Extreme care shall be taken not to disturb the test surface. The spacing of the tests should be such that operations in one area do not disturb the soil in the other area. For testing operations this spacing may be 50 cm for the penetration piston used in the test.

**5.2** If actual service conditions in the field warrant, the surface to be tested may be soaked to the desired degree. During the process of soaking the required surcharge weights should be kept in place. The test surface should be drained of all free water, levelled and allowed to stand for at least 15 minutes before starting further operations.

**5.3** The equipment used to provide load reaction ( truck, tractor, truss etc ), should be so located that the centre of the beam against which the loading jack will work is over the centre of the surface to be tested. If loaded truck or tractor is used for providing the necessary reaction, the rear wheels of the truck or tractor should be completely raised by means of the track type jacks placed below the frame of the body near the wheels in order to avoid the loss of loading effort which would otherwise be spent on the flexing of the axial springs of the vehicle at the time of testing. In order to avoid accidents due to the failure of jacks near the wheels and the lifting of the vehicle at higher loads, the rear side of the body of the vehicle should be placed over two rigid supports. The screw jack with swivel should be installed to the underside of the equipment providing reaction, at the correct position for the test. The proving ring should be connected to the bottom end of the jack and the piston connector to the bottom of the proving ring. The piston should then be connected using, if necessary, lengths of extension

pipes or rods. It should be ensured that the entire assembly is plumb and the loading jack should be clamped in position.

**5.4** The surcharge annular weight of mass 5 kg should be kept in position on the surface to be tested so that when the piston is lowered, it will pass through the hole in the annular weight. The penetration piston should be seated with the smallest possible load not exceeding a total load of 40 N ( or unit load of 0.02 MPa ) so that full contact is established between the piston and the surface to be tested. For materials with irregular surface the piston may be seated on a thinnest practical layer of fine limestone screening or plaster of Paris spread over the surface.

**5.5** While the seating load is on the piston, a 3 to 6 mm layer of clean sand should be spread over the surface to be covered by the surcharge annular weight. This helps in distributing the surcharge load over the surface uniformly.

**5.6** Surcharge weights, sufficient to produce an intensity of loading, equal to the weight of the base material and pavement, except that the minimum weight applied should be 150 N including that of the annular weight [ this weight gives an intensity of loading approximately equal to that in the laboratory bearing ratio test [ see IS 2720 ( Part 16 ) : 1987 ] should be applied. The penetration indicating dial should be suitably fixed for reading the penetration and the dial set to zero. A diagrammatic set up of the test is shown in Fig. 1.

**5.7** Load shall be applied on the penetration piston so that the penetration is approximately 1.25 mm/min. The load readings shall be recorded at penetration of 0.5, 1.0, 1.5, 2.0, 2.5, 3.0, 4.0, 5.0, 7.5, 10.0 and 12.5 mm. The maximum load and penetration shall be recorded if it occurs for a penetration less than 12.5 mm. The set up may then be dismantled.

**5.8** After the completion of the test, a sample shall be collected from the point of penetration, for moisture content determination. The moisture content shall be determined in accordance with IS 2720 ( Part 2 ) : 1973. Besides the moisture content, the in-place density shall be determined in accordance with IS 2720 ( Part 28 ) : 1974 or IS 2720 ( Part 29 ) : 1975 about 15 cm away from the point of penetration.

### 6 CALCULATIONS

#### 6.1 Load Penetration Curve

The load penetration curve shall be plotted ( see Fig. 2 ). This curve may be convex upwards although the initial portion of the curve may be concave upwards due to surface irregularities. A correction shall then be applied by drawing a tangent to the curve at the point of maximum slope. The corrected curve shall

be taken to be this tangent, together with the convex portion of the original curve, with the origin of strains shifted to the point where the tangent cuts the horizontal axis for penetration, as illustrated in Fig. 2.

**6.2 Bearing Ratio**

Corresponding to the penetration value at which the bearing ratio is desired, corrected load values shall be taken from the load penetration curve and the bearing ratio calculated as

follows:

$$\text{Bearing ratio} = \frac{P_t}{P_s} \times 100 \text{ percent}$$

where

$P_t$  = corrected unit (or total) test load corresponding to the chosen penetration value read from the load penetration curve, in MPa (or N);

$P_s$  = unit (or total) standard load for the same depth of penetration as per  $P_t$ , taken from Table 1, in MPa (or N).

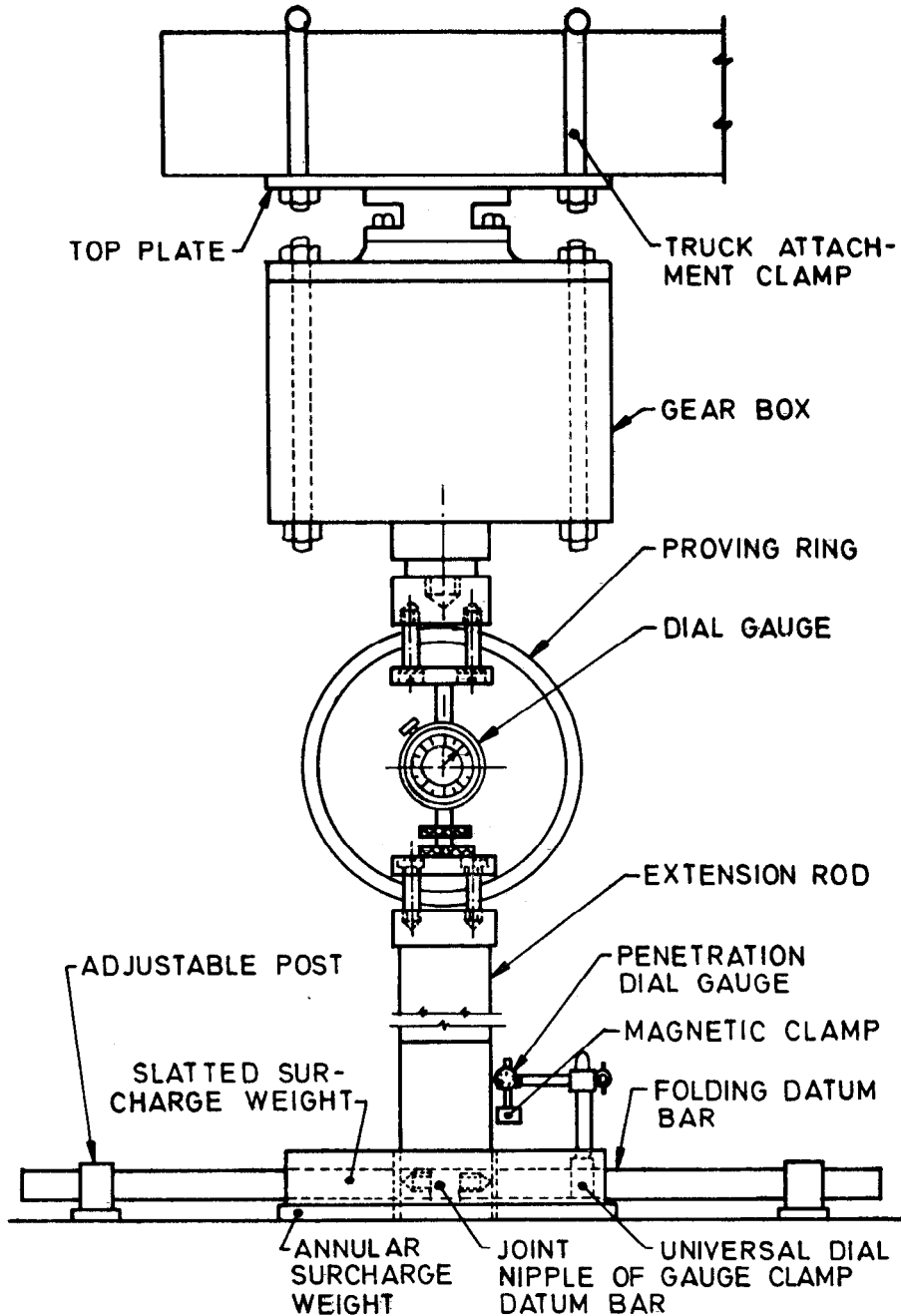

FIG. 1 FIELD CBR APPARATUS

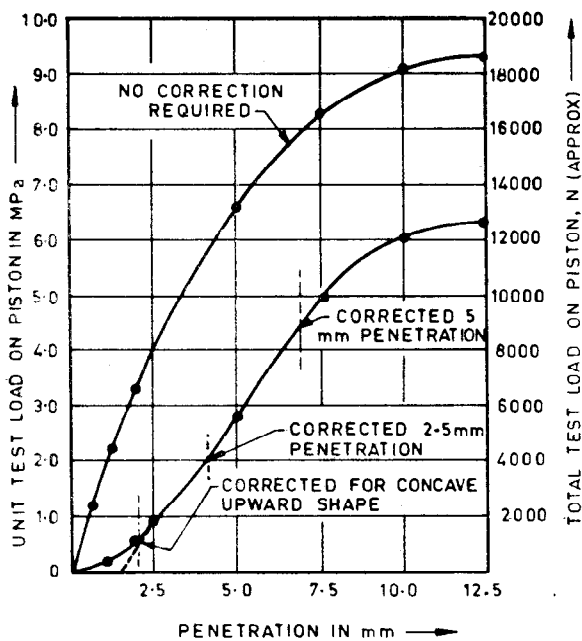

FIG. 2 TYPICAL LOAD PENETRATION CURVES

Table 1 Standard Load,  $P_s$   
( Clause 6.2 )

Penetration Depth mm	Unit Standard Load MPa	Total Standard Load N
2.5	6.86	13 430
5.0	10.30	20 150
7.0	13.10	25 790
10.0	15.90	31 180
12.5	17.90	35 300

6.2.1 The bearing ratios are usually calculated for penetration of 2.5 mm and 5 mm. Generally the bearing ratio at 2.5 mm penetration will be greater than that at 5 mm penetration and in such a case the former shall be taken as the bearing ratio for design purposes. If the bearing ratio corresponding to a penetration of 5 mm exceeds that for 2.5 mm, the test shall be repeated. If identical results follow, the bearing ratio corresponding to 5 mm penetration shall be taken for design.

7 REPORT

7.1 The bearing ratio shall be reported correct to the first decimal place. The details in the recommended proforma for the record of test results given in Annex B shall be given.

8 NUMBER OF FIELD TESTS

8.1 Three in-place bearing ratio tests shall be performed at each location to be tested. However, if the results of the three tests in any group do not show reasonable agreement, three additional tests shall be performed at the same location and numerical average of the six tests shall be used as the bearing ratio at that location. A reasonable agreement between the minimum and maximum values of the three tests where the bearing ratio is less than 10% permits a tolerance of 3%, from 10% to 30% a tolerance of 5%, from 30% to 60% a tolerance of 10%, and greater than 60%, a tolerance of 25%. If it is known that single value is erratic for any reason, that value should be discarded and another test performed.

ANNEX A

( Clause 2.1 )

LIST OF REFERRED INDIAN STANDARDS

IS No.	Title	IS No.	Title
2720 ( Part 2 ) : 1973	Methods of test for soils Determination of water content ( second revision )	( Part 28 ) : 1974	Determination of dry density of soils in-place, by the sand replacement method ( first revision )
( Part 11 ) : 1971	Determination of the shear strength parameters of a specimen tested in unconsolidated undrained triaxial compression without the measurement of pore water pressure	( Part 29 ) : 1975	Determination of dry density of soils in-place, by the core cutter method ( first revision )
( Part 16 ) : 1987	Laboratory determination of CBR ( second revision )	2809 : 1972	Glossary of terms and symbols relating to soil engineering ( first revision )

**ANNEX B**  
( Clause 7.1 )

**PROFORMA FOR IN-PLACE BEARING RATIO TEST**

Location.....Tested by.....

Material at the test point .....Date.....

Depth of tests point.....

Condition of test  $\frac{\text{soaked}}{\text{unsoaked}}$

Period of soaking, if any.....

Surcharge weight used during soaking.....

Moisture content.....

Density.....

Method used for determination of density.....

Penetration test

Surcharge weight used.....

<i>Penetration</i> mm	<i>Proving Ring Dial</i> <i>Gauge Readings</i>	<i>Load</i> N	<i>Corrected Load</i> N ( see 6.1 )
0.5			
1.0			
1.5			
2.0			
2.5			
3.0			
4.0			
5.0			
7.5			
10.0			
12.5			

Bearing ratio at 2.5 mm penetration  $\left. \begin{matrix} 1 \\ 2 \\ 3 \end{matrix} \right\}$  Average

Bearing ratio at 5 mm penetration  $\left. \begin{matrix} 1 \\ 2 \\ 3 \end{matrix} \right\}$  Average

Reasons if test is rejected:

Result of repeat test, if conducted .....

**Standard Mark**

The use of the Standard Mark is governed by the provisions of the *Bureau of Indian Standards Act, 1986* and the Rules and Regulations made thereunder. The Standard Mark on products covered by an Indian Standard conveys the assurance that they have been produced to comply with the requirements of that standard under a well defined system of inspection, testing and quality control which is devised and supervised by BIS and operated by the producer. Standard marked products are also continuously checked by BIS for conformity to that standard as a further safeguard. Details of conditions under which a licence for the use of the Standard Mark may be granted to manufacturers or producers may be obtained from the Bureau of Indian Standards.



## Bureau of Indian Standards

BIS is a statutory institution established under the *Bureau of Indian Standards Act, 1986* to promote harmonious development of the activities of standardization, marking and quality certification of goods and attending to connected matters in the country.

### Copyright

BIS has the copyright of all its publications. No part of these publications may be reproduced in any form without the prior permission in writing of BIS. This does not preclude the free use, in the course of implementing the standard, of necessary details, such as symbols and sizes, type or grade designations. Enquiries relating to copyright be addressed to the Director ( Publications ), BIS.

### Revision of Indian Standards

Indian Standards are reviewed periodically and revised, when necessary and amendments, if any, are issued from time to time. Users of Indian Standards should ascertain that they are in possession of the latest amendments or edition. Comments on this Indian Standard may be sent to BIS giving the following reference:

Doc : No. CED 23 ( 4450 )

#### Amendments Issued Since Publication

Amend No.	Date of Issue	Text Affected

## BUREAU OF INDIAN STANDARDS

### Headquarters :

Manak Bhavan, 9 Bahadur Shah Zafar Marg, New Delhi 110002  
Telephones : 331 01 31, 331 13 75

Telegrams : Manaksanstha  
( Common to all Offices )

### Regional Offices :

Central : Manak Bhavan, 9 Bahadur Shah Zafar Marg  
NEW DELHI 110002

Telephone

{ 331 01 31  
331 13 75

Eastern : 1/14 C. I. T. Scheme VII M, V. I. P. Road, Maniktola  
CALCUTTA 700054

87 86 62

Northern : SCO 445-446, Sector 35-C, CHANDIGARH 160036

53 38 43

Southern : C. I. T. Campus, IV Cross Road, MADRAS 600113

41 29 16

Western : Manakalaya, E9 MIDC, Marol, Andheri ( East )  
BOMBAY 400093

6 32 92 95

Branches : AHMADABAD. BANGALORE. BHOPAL. BHUBANESWAR.  
COIMBATORE. FARIDABAD. GHAZIABAD. GUWAHATI.  
HYDERABAD. JAIPUR. KANPUR. PATNA. THIRUVANATHAPURAM.