

IS : 2720 (Part XXVIII) - 1974
(Reaffirmed 1995)

Indian Standard

METHODS OF TEST FOR SOILS

PART XXVIII DETERMINATION OF DRY DENSITY
OF SOILS IN-PLACE, BY THE SAND
REPLACEMENT METHOD

(*First Revision*)

Sixth Reprint AUGUST 1998

UDC 624.131.431.5

© Copyright 1974

BUREAU OF INDIAN STANDARDS

MANAK BHAVAN, 9 BAHADUR SHAH ZAFAR MARG

NEW DELHI 110002

Indian Standard

METHODS OF TEST FOR SOILS

PART XXVIII DETERMINATION OF DRY DENSITY OF SOILS IN-PLACE, BY THE SAND REPLACEMENT METHOD

(*First Revision*)

Soil Engineering Sectional Committee, BDC 23

Chairman

PROF DINESH MOHAN

Representing

Central Building Research Institute (CSIR),
Roorkee

Members

SHRI G. R. S. JAIN (*Alternate to*
Prof Dinesh Mohan)

PROF ALAM SINGH
DR A. BANERJEE

University of Jodhpur, Jodhpur
Cementation Co Ltd, Bombay

SHRI S. GUPTA (*Alternate*)

SHRI K. N. DADINA
SHRI A. G. DASTIDAR

In personal capacity (*P-820 New Alipore, Calcutta 53*)
Hindustan Construction Co, Bombay

SHRI R. L. DEWAN
DR G. S. DHILLON

Irrigation Research Institute, Khagaul, Patna
Indian Geotechnical Society, New Delhi
Indian Institute of Technology, New Delhi

DIRECTOR

PROF S. K. GULHATI (*Alternate*)

DIRECTOR

Irrigation & Power Research Institute, Amritsar

SHRI B. B. L. BHATNAGAR (*Alternate*)

DIRECTOR (CS & MRS)

Central Water & Power Commission, New Delhi

DEPUTY DIRECTOR (CS & MRS)

(*Alternate*)

SHRI A. H. DIVANJI

Rodio Foundation Engineering Ltd; and Hazarat &
Co, Bombay

SHRI A. N. JANGLE (*Alternate*)

SHRI V. G. HEGDE

National Buildings Organization, New Delhi

SHRI J. P. SHARMA (*Alternate*)

DR IQBAL ALI

Engineering Research Laboratory, Hyderabad

SHRI K. R. SAXENA (*Alternate*)

JOINT DIRECTOR RESEARCH (FE),

Railway Board (Ministry of Railways)

RDSO

DEPUTY DIRECTOR RESEARCH,

SOIL MECHANICS, RDSO (*Alternate*)

(*Continued on page 2*)

© Copyright 1974

BUREAU OF INDIAN STANDARDS

This publication is protected under the *Indian Copyright Act* (XIV of 1957) and reproduction in whole or in part by any means except with written permission of the publisher shall be deemed to be an infringement of copyright under the said Act.

(Continued from page 1)

<i>Members</i>	<i>Representing</i>
SHRI O. P. MALHOTRA	Public Works Department, Government of Punjab
SHRI J. S. MARYA	Roads Wing (Ministry of Shipping & Transport)
SHRI A. S. BISHNOI (<i>Alternate</i>)	
SHRI M. A. MEHTA	Concrete Association of India, Bombay
SHRI T. M. MENON (<i>Alternate</i>)	
SHRI T. K. NATARAJAN	Central Road Research Institute (CSIR), New Delhi
RESEARCH OFFICER	Buildings & Roads Research Laboratory, Public Works Department, Government of Punjab
MAJ K. M. S. SAHASI	Engineer-in-Chief's Branch, Army Headquarters
SHRI P. PUTHISIGAMANI (<i>Alternate</i>)	
SECRETARY	Central Board of Irrigation & Power, New Delhi
DEPUTY SECRETARY (<i>Alternate</i>)	
DR SHAMSHER PRAKASH	University of Roorkee, Roorkee
SHRI H. D. SHARMA	Irrigation Research Institute, Roorkee
SUPERINTENDING ENGINEER (PLANNING & DESIGN CIRCLE)	Concrete & Soil Research Laboratory, Public Works Department, Government of Tamil Nadu
EXECUTIVE ENGINEER (INCHARGE SOIL MECHANICS & RESEARCH DIVISION) (<i>Alternate</i>)	
SHRI C. G. SWAMINATHAN	Institution of Engineers (India), Calcutta
SHRI H. C. VERMA	All India Instrument Manufacturers & Dealers Association, Bombay
SHRI V. K. VASUDEVAN (<i>Alternate</i>)	
SHRI H. G. VERMA	Public Works Department, Government of Uttar Pradesh
SHRI D. C. CHATURVEDI (<i>Alternate</i>)	
SHRI D. AJITHA SMHA, Director (Civ Engg)	Director General, BIS (<i>Ex-officio Member</i>)

Secretary

SHRI G. RAMAN

Deputy Director (Civ Engg), BIS

Soil Testing Procedures and Equipment Subcommittee, BDC 23 : 3

Convener

PROF ALAM SINGH

University of Jodhpur, Jodhpur

Members

SHRI N. K. BERRY

Beas Dams Project, Talwara Township

SHRI N. K. AHUJA (*Alternate*)

DR R. K. BHANDARI

Central Road Research Institute (CSIR), New Delhi
Roads Wing (Ministry of Shipping & Transport)

SHRI T. N. BHARGAWA

SHRI A. S. BISHNOI (*Alternate*)

DR A. K. CHATTERJEE

Public Works Department, Government of Uttar Pradesh

DR B. L. DHAWAN (*Alternate*)

SHRI R. L. DEWAN

Irrigation Research Institute, Khagaul, Patna
Central Water & Power Commission, New Delhi

DIRECTOR (CS & MRS)

DEPUTY DIRECTOR (CS & MRS)

(*Alternate*)

(Continued on page 21)

Indian Standard

METHODS OF TEST FOR SOILS

PART XXVIII DETERMINATION OF DRY DENSITY OF SOILS IN-PLACE, BY THE SAND REPLACEMENT METHOD

(First Revision)

0. FOREWORD

0.1 This Indian Standard (Part XXVIII) (First Revision) was adopted by the Indian Standards Institution on 21 February 1974, after the draft finalized by the Soil Engineering Sectional Committee had been approved by the Civil Engineering Division Council.

0.2 With a view to establish uniform procedures for the determination of different characteristics of soils and also for facilitating comparative studies of the results, the Indian Standards Institution is bringing out this Indian Standard methods of test for soils (IS : 2720) which will be published in parts. This part [IS ; 2720 (Part XXVIII)] deals with the determination of dry density of soil, in-place, by the sand replacement method. The in-place density of natural soil is needed for the determination of bearing capacity of soils, for the purpose of stability analysis of natural slopes, for the determination of pressures on underlying strata for calculation of settlement, etc. In compacted soils the in-place density is needed to check the amount of compaction that the soil has undergone for comparison with design data. The correct estimation of the in-place density of both natural and compacted soils is therefore of importance.

0.2.1 This standard was originally published in 1966. In this revision the sieve size for defining fine-grained soils has been changed to 2 mm. An appendix has been added for the determination of water content and dry density of medium- and coarse-grained soils containing appreciable gravel fraction.

0.3 This standard is divided into two sections. Section 1 prescribes the method suitable for fine- and medium-grained soils using the small sand pouring cylinder; Section 2 lays down the method which uses the large sand pouring cylinder and is suitable for fine-, medium- and coarse-grained soils containing stones which make the test of Section 1 difficult to perform.

IS : 2720 (Part XXVIII) - 1974

0.3.1 For the purpose of tests described in this standard soils shall be grouped as shown below:

Fine-grained soils	Soils containing not less than 90 percent passing a 2.0-mm IS Sieve (see IS : 460-1962*)
Medium-grained soils	Soils containing not less than 90 percent passing a 20-mm IS Sieve (see IS : 460-1962*)
Coarse-grained soils	Soils containing not less than 90 percent passing a 40-mm IS Sieve (see IS : 460-1962*)

0.4 The other standards so far published relating to the determination of density of soil in-place are as follows:

IS : 2720 (Part XXIX)-1966 Methods of test for soils: Part XXIX Determination of dry density of soils in-place by the core cutter method

IS : 2720 (Part XXXIII)-1971 Methods of test for soils: Part XXXIII Determination of density in-place by the ring and water replacement method

IS : 2720 (Part XXXIV)-1972 Methods of test for soils: Part XXXIV Determination of density of soil in-place by the rubber-balloon method

0.5 In the formulation of this standard due weightage has been given to international co-ordination among the standards and practices prevailing in different countries in addition to relating it to the practices in the field in this country. This has been met by basing the standard on the following publications:

BS 1377 : 1961 Methods of testing soils for civil engineering purposes. British Standards Institution.

INDIA. MINISTRY OF IRRIGATION AND POWER. CBIP Publication No. 42. Standards for testing soils. 1963. Central Board of Irrigation and Power, New Delhi.

0.6 In reporting the result of a test or analysis made in accordance with this standard, if the final value, observed or calculated, is to be rounded off, it shall be done in accordance with IS : 2-1960†.

*Specification for test sieves (revised).

†Rules for rounding off numerical values (revised).

SECTION 1 METHOD SUITABLE FOR FINE- AND MEDIUM-GRAINED SOILS : SMALL POURING CYLINDER METHOD

1. SCOPE

1.1 This method covers the determination, in-place, of the dry density (in g/cm^3 or kg/m^3) of natural or compacted fine- and medium-grained soils for which a small sand-pouring cylinder is used. The method is applicable to layers not exceeding 150 mm in thickness (*see* Note).

NOTE — With granular materials having little or no cohesion, particularly when they are wet, there is a danger of errors in the measurement of dry density by this method. These errors are caused by the slumping of the sides of the excavated density hole and always result in an over-estimation of the density.

2. APPARATUS

2.1 Small Sand-Pouring Cylinder — similar in essential details to that shown in Fig. 1.

2.2 Tools for Excavating Holes — suitable tools, such as a scraper tool similar to that shown in Fig. 2 to make a level surface; bent spoon, dibber shown in Fig. 3.

2.3 Cylindrical Calibrating Container — with an internal diameter of 100 mm and an internal depth of 150 mm (*see* Note 1 under 4.2.2) of the type illustrated in Fig. 4 fitted with a flange approximately 50 mm wide and about 5 mm thick surrounding the open end. The volume of the container should be given to an accuracy of 0.25 percent.

2.4 Balance — accurate to 1 g.

2.5 Plane Surface: Glass or Perspex Plate or Other Plane Surface — about 450 mm square and 9 mm thick or larger.

2.6 Metal Containers — to collect excavated soil. A convenient size is one about 150 mm diameter and 200 mm deep with a removable cover.

2.7 Cylindrical Steel Core-Cutter — of steel, 127.4 ± 0.1 mm long and 100 mm ± 0.1 mm internal diameter with a wall thickness of 3 mm bevelled at one end. One suitable type is illustrated in Fig. 5. The cutter shall be kept adequately greased.

2.8 Metal Tray with Hole — 300 mm square and 40 mm deep with a 100 mm hole in the centre.

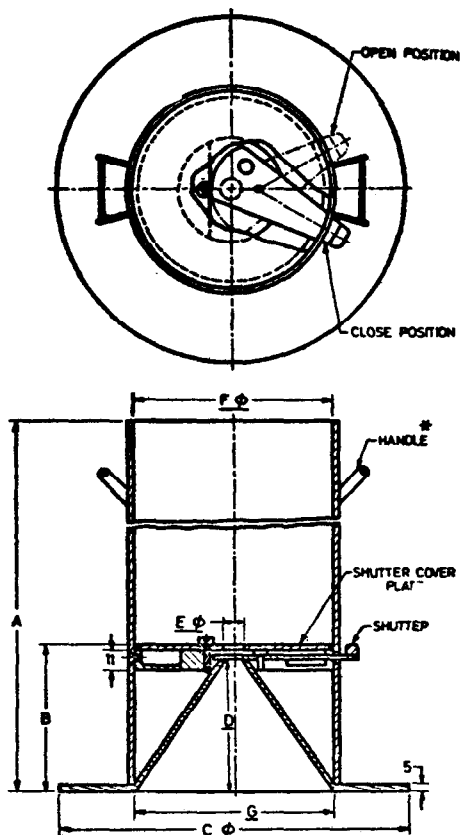

*The handle may be required for large pouring cylinder only.

Pouring Cylinder Size	<u>A</u>	<u>B</u>	<u>C</u>	<u>D</u>	<u>E</u>	<u>F</u>	<u>G</u>	Capacity in Litres
Small (for fine- and medium-grained soils)	380	85	200	75	13 ± 0.1	115	115	3
Large (for fine-, medium- and coarse-grained soils)	610	175	350	160	25 ± 0.1	215	215	16.5

NOTE 1 — This design has been found satisfactory, but alternative designs may be employed, provided that the essential requirements are fulfilled.

NOTE 2 — Essential dimensions are underlined.

NOTE 3 — Tolerance on essential dimensions ± 1 mm.

All dimensions in millimetres.

FIG. 1 SAND-POURING CYLINDER FOR THE DETERMINATION OF DENSITY

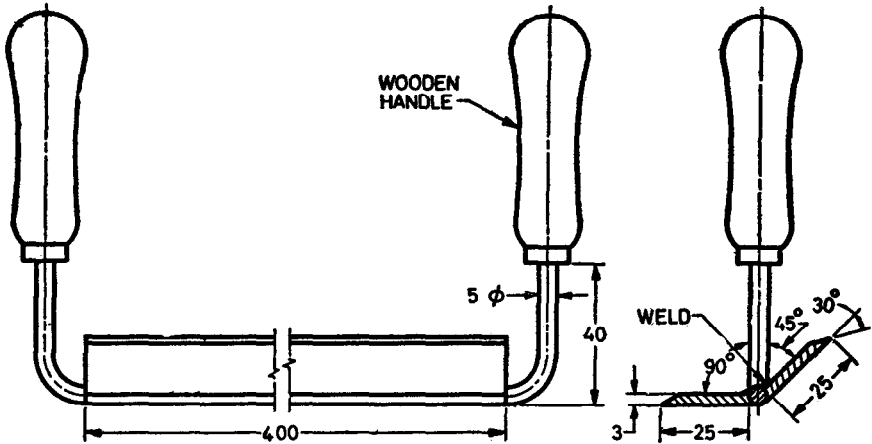

NOTE — This design has been found satisfactory, but alternative designs may be employed.

All dimensions in millimetres.

FIG. 2 SCRAPER FOR LEVELLING SURFACE OF SOIL

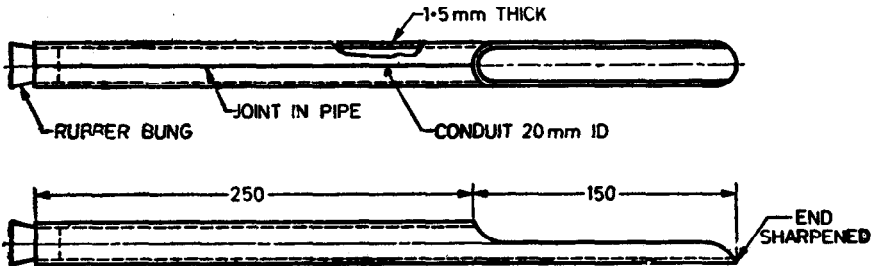

NOTE — This design has been found satisfactory, but alternative designs may be employed.

All dimensions in millimetres.

FIG. 3 DIBBER FOR DIGGING DENSITY HOLES

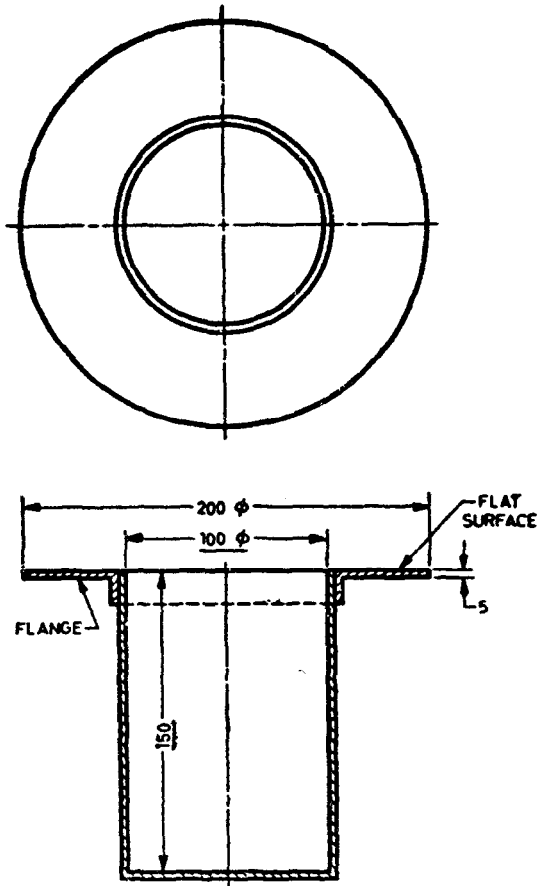

NOTE 1 — This design has been found satisfactory, but alternative designs may be employed, provided that the essential requirements are fulfilled.

NOTE 2 — Essential dimensions are underlined.

NOTE 3 — Tolerance on essential dimensions ± 0.1 mm.

All dimensions in millimetres.

FIG. 4 CALIBRATING CONTAINER FOR USE WITH SMALL POURING CYLINDER

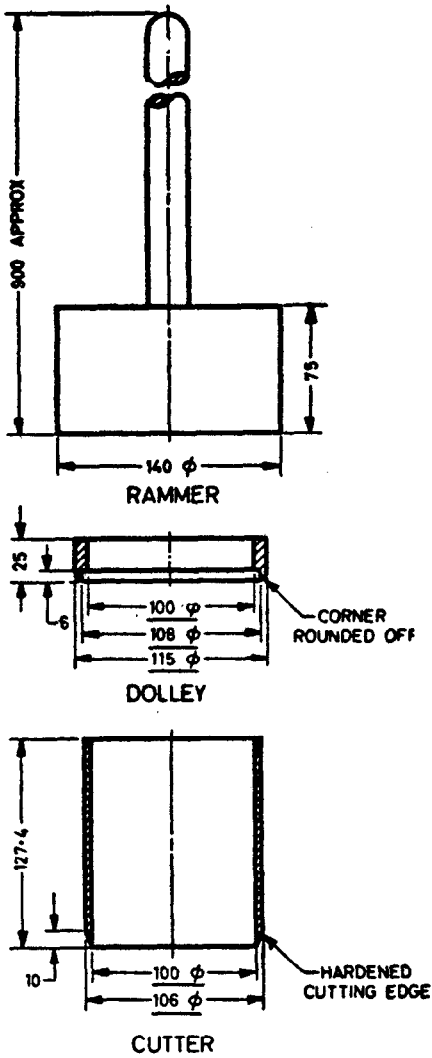

All dimensions in millimetres.

NOTE 1 — These designs have been found satisfactory, but alternative designs may be employed, provided that the essential requirements are fulfilled.

NOTE 2 — Essential dimensions are underlined.

NOTE 3 — Tolerance on essential dimensions ± 0.1 mm.

FIG. 5 CORE-CUTTER APPARATUS FOR SOIL DENSITY DETERMINATION

3. MATERIAL (SAND)

3.1 Clean, uniformly graded natural sand passing the 1.00-mm IS Sieve and retained on the 600-micron IS Sieve shall be used. It shall be free from organic matter, and shall have been oven dried and stored for a suitable period to allow its water content to reach equilibrium with atmospheric humidity (*see* Note).

NOTE — Generally a storage period, after oven drying, of about 7 days is sufficient for the water content of the sand to reach equilibrium with the atmospheric humidity. The sand should not be stored in air-tight containers and should be thoroughly mixed before use. If sand is salvaged from holes in compacted soils after carrying out the test, it is advisable to sieve, dry and store this sand again before it is used in further sand replacement tests.

4. PROCEDURE

4.1 Calibration of Apparatus

4.1.1 The method given in **4.1.1.1** to **4.1.1.4** shall be followed for the determination of the weight of sand in the cone of the pouring cylinder.

4.1.1.1 The pouring cylinder shall be filled so that the level of the sand in the cylinder is within about 10 mm of the top. Its total initial weight (W_1) shall be found and shall be maintained constant throughout the tests for which the calibration is used. A volume of sand equivalent to that of the excavated hole in the soil (or equal to that of the calibrating container) (*see* Note 1 under **4.2.2**) shall be allowed to run out of the cylinder under gravity. The shutter on the pouring cylinder shall then be closed and the cylinder placed on a plane surface, such as a glass plate.

4.1.1.2 The shutter on the pouring cylinder shall be opened and sand allowed to run out. When no further movement of sand takes place in the cylinder the shutter shall be closed and the cylinder removed carefully.

4.1.1.3 The sand that has filled the cone of the pouring cylinder (that is, the sand that is left on the plane surface) shall be collected and weighed to the nearest gram.

4.1.1.4 These measurements shall be repeated at least three times and the mean weight (W_2) taken.

4.1.2 The method described in **4.1.2.1** to **4.1.2.3** shall be followed for the determination of the bulk density of the sand (γ_s).

4.1.2.1 The internal volume (V) in ml of the calibrating container shall be determined from the weight of water contained in the container when filled to the brim (*see* Note 1 under **4.2.2**). The volume may also be calculated from the measured internal dimensions of the container.

4.1.2.2 The pouring cylinder shall be placed concentrically on the top of the calibrating container after being filled to the constant weight (W_1) as in 4.1.1.1. The shutter on the pouring cylinder shall be closed during this operation. The shutter shall be opened and sand allowed to run out. When no further movement of sand takes place in the cylinder the shutter shall be closed. The pouring cylinder shall be removed and weighed to the nearest gram.

4.1.2.3 These measurements shall be repeated at least three times and the mean weight (W_3) taken (*see* Note).

NOTE — Since variations in atmospheric humidity affect the water content of the sand, and hence its bulk density, the calibration should be made (or at least checked) during each day's work. To overcome the effects of slight variations in grading and particle shape between batches of sand, each batch should be sampled and calibrated.

4.2 Measurement of Soil Density — The following method shall be followed for the measurement of soil density.

4.2.1 A flat area, approximately 450 mm square, of the soil to be tested shall be exposed and trimmed down to a level surface preferably with the aid of the scraper tool.

4.2.2 The metal tray with a central hole shall be laid on the prepared surface of the soil with the hole over the portion of the soil to be tested. The hole in the soil shall then be excavated using the hole in the tray as a pattern, to the depth of the layer to be tested up to a maximum of 150 mm (*see* Note 1). The excavated soil shall be carefully collected, leaving no loose material in the hole and weighed to the nearest gram (W_w). The metal tray shall be removed before the pouring cylinder is placed in position over the excavated hole.

The following alternative method shall be used for fine-grained cohesionless soils:

The steel core cutter shall be pressed evenly and carefully into the soil until its top edge is flush with the levelled surface. Soil to a depth of 100 mm (*see* Note 1) within the core cutter shall then be excavated by means of suitable tools. The excavated soil shall be carefully collected and weighed to the nearest gram (W_w). The core cutter shall remain in position during the remainder of the testing procedure.

NOTE 1 — If for any reason it is necessary to excavate the holes to depths other than 150 mm, the calibrating container should be replaced by one, the depth of which is the same as the hole excavated or its effective depth should be reduced to that of the hole excavated.

NOTE 2 — Care shall be taken in excavating the hole to see that the hole is not enlarged by levering the dibber against the side of the hole, as this will result in lower densities being recorded.

4.2.3 The water content (W) of the excavated soil shall be determined by the method specified in IS : 2720 (Part II)-1973*. Alternatively the whole of the excavated soil may be dried and weighed (W_4).

4.2.4 The pouring cylinder filled to the constant weight (W_1) as in 4.1.1 shall be so placed that the base of the cylinder covers the hole concentrically. The shutter on the pouring cylinder shall be closed during this operation. The shutter shall then be opened and sand allowed to run out into the hole. The pouring cylinder and the surrounding area shall not be vibrated during this period. When no further movement of sand takes place the shutter shall be closed. The cylinder shall be removed and weighed to the nearest gram (W_4) (see Note).

NOTE — It is necessary to make a number of repeated determinations (at least three) and to average the results, since the dry density of the soil varies appreciably from point to point. The number of determinations should be such that an additional one would make no significant difference to the average.

5. CALCULATIONS

5.1 The weight of sand (W_a) in g, required to fill the calibrating container shall be calculated from the following formula:

$$W_a = W_1 - W_3 - W_2$$

where

W_1 = weight of pouring cylinder and sand before pouring into calibrating container in g,

W_3 = mean weight of cylinder with residual sand after pouring into calibrating container and cone in g, and

W_2 = mean weight of sand in cone in g.

5.2 The bulk density of the sand (γ_s) in kg/m^3 shall be calculated from the formula:

$$\gamma_s = \frac{W_a}{V} \times 1000$$

where

V = volume of calibrating container in ml.

5.3 The weight of sand (W_b) in g, required to fill the excavated hole shall be calculated from the following formula:

$$W_b = W_1 - W_4 - W_3$$

*Methods of test for soils: Part II Determination of water content (second revision).

where

W_1 = weight of cylinder and sand before pouring into hole in g,

W_4 = weight of cylinder and sand after pouring into hole and cone in g, and

W_2 = mean weight of sand in cone in g.

5.4 The bulk density γ_b , that is, the weight of the wet soil per cubic metre shall be calculated from the following formula:

$$\gamma_b = \frac{W_w}{W_b} \times \gamma_s \text{ kg/m}^3$$

where

W_w = weight of soil excavated in g,

W_b = weight of sand required to fill the hole in g, and

γ_s = bulk density of sand in kg/m^3 .

5.5 The dry density γ_d , that is, the weight of the dry soil shall be calculated from the following formula:

$$\gamma_d = \frac{100 \gamma_b}{100 + w} \text{ kg/m}^3$$

or

$$\gamma_d = \frac{W_d}{W_b} \times \gamma_s \text{ kg/m}^3$$

where

w = water content of the soil in percent,

W_d = weight of dry soil from the hole in g, and

W_b = weight of sand required to fill the hole in g.

6. REPORTING OF RESULTS

6.1 The following values shall be reported:

- a) Dry density of soil in kg/m^3 to the nearest whole number. The dry density may also be calculated and reported in g/cm^3 correct to the second place of decimal.
- b) Water content of the soil in percent reported to two significant figures.

6.2 The method used for obtaining the test results shall be stated as the small pouring cylinder method. The use of steel core cutter, if made, shall also be mentioned.

6.3 The results of the test shall be recorded suitably. A recommended pro forma for the record of the test results is given in Appendix A.

SECTION 2 METHOD SUITABLE FOR FINE-, MEDIUM- AND COARSE-GRAINED SOILS: LARGE POURING CYLINDER METHOD

7. SCOPE

7.1 This method covers the determination, in-place, of the dry density (in g/cm^3 or kg/m^3) of natural or compacted soil containing stones which make the test of Section 1 difficult to perform. This is an alternative method of test to Section 1 for fine- and medium-grained soils and should be used instead of that test for layers exceeding 150 mm but not exceeding 250 mm in thickness (*see* Note under **1.1**).

8. APPARATUS

8.1 Large Sand-Pouring Cylinder — similar in the essential details to that shown in Fig. 1.

8.2 Tools for Excavating Holes — suitable tools, such as bent spoon, dibber (*see* Fig. 3), large screw driver, pointed steel rod about 300 mm long and 5 to 10 mm dia with a wooden handle.

8.3 Cylindrical Calibrating Container — with internal diameter of 200 mm and an internal depth of 250 mm (*see* Note 1 under **4.2.2**) of the type illustrated in Fig. 6 fitted with a flange 75 mm wide and about 5 mm thick surrounding the open end. The volume of the container should be given to an accuracy of 0.15 percent.

8.4 Balance — accurate to 1 g.

8.5 Plane Surface — a glass plate or other plane surface about 600 mm square and 10 mm thick or larger.

8.6 Metal Containers — to collect the excavated soil and to take the supply of sand to fill the pouring cylinder. This may be provided with a suitable cover.

8.7 Metal Tray with Central Hole — a metal tray 450 mm square and 50 mm deep with a 200 mm dia hole in the centre.

9. MATERIAL (SAND)

9.1 Clean, uniformly graded natural sand passing the 1.00-mm IS Sieve and retained on the 600-micron IS Sieve shall be used. It shall be free from organic matter, and shall have been oven dried and stored for a suitable period to allow its water content to reach equilibrium with atmospheric humidity (*see* Note under **3.1**).

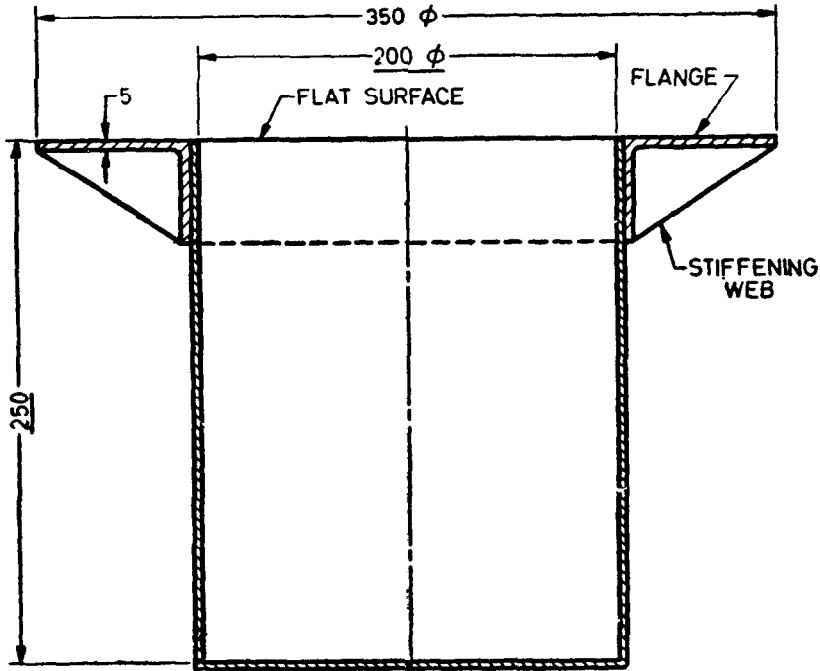

NOTE 1 — This design has been found satisfactory, but alternative designs may be employed, provided that the essential requirements are fulfilled.

NOTE 2 — Essential dimensions are underlined.

NOTE 3 — Tolerance on essential dimensions ± 0.1 mm.

All dimensions in millimetres.

FIG. 6 CALIBRATING CONTAINER FOR USE WITH LARGE POURING CYLINDER AND IN THE HAND SCOOP METHOD

10. PROCEDURE

10.1 Calibration of Apparatus

10.1.1 The method described in **10.1.1.1** to **10.1.1.4** shall be followed for the determination of the weight of sand in the cone of the pouring cylinder.

10.1.1.1 The pouring cylinder shall be filled with a given initial weight of sand (W_1). This weight shall be maintained constant throughout the tests for which the calibration is used (*see* Note). A volume of sand equivalent to that of the excavated hole in the soil (or equal to that

of the calibrating container) shall be allowed to run out of the pouring cylinder under gravity. The shutter on the pouring cylinder shall then be closed and the cylinder placed on the plane surface.

NOTE — The total weight of the pouring cylinder and sand is large, so that the method of filling and weighing is to weigh the sand in two or three containers and tip it into the pouring cylinder before using. Care shall be taken to see that the same constant initial weight as is used in calibrating the apparatus is used for each density measurement. Sufficient sand should be used to leave about 4 to 5 kg of sand in the pouring cylinder after the test is completed.

10.1.1.2 The shutter on the pouring cylinder shall be opened and sand allowed to run out. When no further movement of sand takes place in the cylinder the shutter shall be closed and the cylinder removed carefully.

10.1.1.3 The sand that has filled the cone of the pouring cylinder shall be collected and weighed to the nearest 0.1 percent of its total weight.

10.1.1.4 These measurements shall be repeated at least three times and mean weight (W_2) taken.

10.1.2 The method described in **10.1.2.1** to **10.1.2.3** shall be followed for the determination of the bulk density of the sand (γ_s).

10.1.2.1 The internal volume (V) in ml of the calibrating container shall be determined by the weight of water contained in the container when filled to the brim (*see* Note under **10.2.2**).

10.1.2.2 The calibrating container should stand on a large tray during the procedure to collect the sand overflowing from the cone when the cylinder is removed. The pouring cylinder shall be placed concentrically on the top of the calibrating container and filled with the constant weight of sand (W_1) as in **10.1.1.1**. The shutter on the pouring cylinder shall be closed during this operation. The shutter shall be opened and the sand allowed to run out. When no further movement of the sand takes place in the cylinder the shutter shall be closed. The pouring cylinder shall be removed and the sand remaining in it weighed to the nearest 0.1 percent of its initial weight.

10.1.2.3 These measurements shall be repeated at least three times, and the mean weight (W_3) taken (*see* Note under **4.1.2.3**).

10.2 The method given in **10.2.1** to **10.2.4** shall be followed for the measurement of soil density.

10.2.1 A flat area, approximately 60 cm², at the place at which the soil is to be tested shall be exposed and trimmed down to a level surface.

10.2.2 The metal tray with a central hole shall be laid on the prepared surface of the soil with the hole over the portion of the soil to be tested. The hole in the soil shall then be excavated using the hole in the tray as a pattern, to the depth of the layer to be tested up to a maximum of 250 mm

(see Note). The excavated soil shall be carefully collected, leaving no loose material in the hole, and weighed to the nearest gram (W_w). The metal tray shall be removed before the pouring cylinder is placed in position over the excavated hole.

NOTE — If for any reason it is necessary to excavate holes to depths other than 250 mm the calibrating container should be replaced by one, the depth of which is the same as the hole excavated or its effective depth reduced to that of the hole excavated.

10.2.3 A representative sample of the excavated soil shall be placed in an air-tight container and its water content (w) determined by the method specified in IS : 2720 (Part II)-1973*.

10.2.4 The pouring cylinder filled with the constant weight of sand (W_1) as in 10.1.1.1, shall be placed so that the base of the cylinder covers the hole concentrically. The shutter on the pouring cylinder shall be closed during this operation. The shutter shall then be opened and sand allowed to run out. When no further movement of the sand takes place the shutter shall be closed. The cylinder shall be removed and the sand remaining in it weighed to the nearest 0.1 percent of its initial weight (W_4) (see Note under 4.2.4).

11. CALCULATIONS

11.1 The calculations shall be done as laid down in 5.

11.2 For medium- and coarse-grained soils containing appreciable gravel fraction (plus 4.75-mm IS Sieve) the water content and dry density shall be determined as given in Appendix B.

12. REPORTING OF RESULTS

12.1 The results shall be reported as specified in 6 except that the method used for obtaining the test results shall be stated as large pouring cylinder method.

12.2 The results of the test shall be recorded suitably. A recommended pro forma for the record of test results is given in Appendix A.

*Methods of test for soils: Part II Determination of water content (second revision).

APPENDIX A

(*Clauses 6.3 and 12.2*)

**DETERMINATION OF DRY DENSITY OF SOIL, IN-PLACE,
BY SAND REPLACEMENT**

(**Small Pouring Cylinder/Large Pouring Cylinder**)

A-1. The test results for the two methods, namely, small pouring cylinder and large pouring cylinder may be tabulated as given below using the appropriate symbols and words in each case:

Project: _____ Tested by: _____

Location: _____ Date: _____

State whether steel core cutter was used.

Calibration

1. Mean weight of sand in cone (of pouring cylinder) (W_2), in g

2. Volume of calibrating container (V), in ml

3. Weight of sand (+ cylinder) before pouring (W_1), in g

4. Mean weight of sand (+ cylinder) after pouring (W_3), in g

5. Weight of sand to fill calibrating container ($W_a = W_1 - W_3 - W_2$), in g

6. Bulk density of sand $\gamma_s = \frac{W_a}{V} \times 1000 \text{ kg/m}^3$

Measurement of Soil Density

-
1. Determination No.

 2. Weight of wet soil from hole (W_w), in g

 3. Weight of sand (+ cylinder) before pouring (W_1), in g

 4. Weight of sand (+ cylinder) after pouring (W_4), in g

 5. Weight of sand in hole ($W_b = W_1 - W_4 - W_2$), in g

 6. Bulk density $\gamma_b = \frac{W_w}{W_b} \times \gamma_s$ kg/m³

 7. Water content container No.

 8. Weight of soil for water content determination, in g

 9. Weight of oven dried soil, in g

 10. Water content (w), percent

 11. Dry density $\gamma_d = \frac{100\gamma_b}{100+w}$ kg/m³

APPENDIX B*(Clause 11.2)***DETERMINATION OF WATER CONTENT AND DRY DENSITY OF MEDIUM- AND COARSE-GRAINED SOILS CONTAINING APPRECIABLE GRAVEL FRACTION (PLUS 4.75-mm IS SIEVE)****B-1. IN-PLACE BULK DENSITY**

B-1.1 The in-place bulk density (γ_b) of the soil shall be determined as described in Section 2.

B-2. PROCEDURE FOR DETERMINATION OF VOLUME AND WATER CONTENT

B-2.1 After obtaining the wet weight (W_w) of the total material removed from the hole, the soil shall be separated into plus 4.75-mm fraction

IS : 2720 (Part XXVIII) - 1974

(gravel) and minus 4.75 mm fraction by the 4.75-mm IS Sieve. This should be done rapidly to avoid loss of water.

NOTE — If this test is for construction control, the fraction passing the 4.75-mm IS Sieve should be placed in an air-tight container for further tests.

B-2.2 The fraction retained on the 4.75-mm IS Sieve (gravel) shall be washed on the sieve using a minimum of water, blotted dry with a towel to a wet surface-dry condition and weighed (W'_g).

B-2.3 The volume of the gravel (V_g) in a wet surface-dry condition, shall then be determined by displacement of water from a siphon-container from which the over-flow can be measured, or by weighing in air and in water. The specific gravity (G_g) of the gravel particles should then be computed.

NOTE — For construction control, the volume of gravel need not be measured every time a test is made. After several tests have shown that the specific gravity of the gravel from a particular source is virtually constant, the specific gravity may be assumed and the volume computed.

B-2.4 The wet gravel (W'_g) shall be placed in an oven and the oven-dry weight and water content (w_g) shall be determined.

B-2.5 The water content (w_s) in percent of the soil fraction passing the 4.75-mm IS Sieve shall also be determined by oven-drying a representative sample.

B-3. CALCULATIONS

B-3.1 Further calculations should be carried out as follows:

- a) In-place bulk density γ_b = $\frac{W_w}{\text{Volume of hole}}$
- b) Wet weight of minus 4.75-mm soil = $W_w - W'_g$
- c) Volume of minus 4.75-mm soil = $\text{Volume of hole} - V_g$
- d) Wet density of minus 4.75-mm soil = $\frac{(a)}{(b)}$
- e) Dry weight of minus 4.75-mm soil = $\frac{(a)}{1 + w_s/100}$
- f) Dry density of minus 4.75-mm soil = $\frac{(c)}{1 + w_s/100}$
- g) Dry weight of total material (soil + gravel) = $W'_g + (d)$
- h) Water content (w_T) of total material, percent = $\frac{W_w - (f)}{(f)} \times 100$
- j) Percentage of gravel in the material on a dry weight basis = $\frac{W'_g}{(f)} \times 100$
- k) Dry density of the total material = $\frac{\gamma_b}{1 + w_T/100}$

(Continued from page 2)

Members

SHRI H. K. GUHA
SHRI N. N. BHATTACHARAYA
(Alternate)
SHRI S. K. GULHATI
SHRI G. R. S. JAIN
SHRI AMAR SINGH (Alternate)
SHRI O. P. MALHOTRA
DR I. S. UPPAL (Alternate)
DR V. V. S. RAO
SHRI K. K. GUPTA (Alternate)
MAJ K. M. S. SAHASI
SHRI H. C. VERMA
SHRI M. N. BALIGA (Alternate)

Representing

Geologists' Syndicate Pvt Ltd, Calcutta
Indian Institute of Technology, New Delhi
Central Building Research Institute (CSIR), Roorkee
Buildings & Roads Research Laboratory, Chandigarh
United Technical Consultants Pvt Ltd, New Delhi
Engineer-in-Chief's Branch, Army Headquarters
Associated Instrument Manufacturers (India) Pvt
Ltd, New Delhi

BUREAU OF INDIAN STANDARDS

Headquarters:

Manak Bhavan, 9 Bahadur Shah Zafar Marg, NEW DELHI 110002
Telephones: 323 0131, 323 3375, 323 9402
Fax : 91 11 3234062, 91 11 3239399, 91 11 3239382

Telegrams : Manaksanstha
(Common to all Offices)

Central Laboratory:

Plot No. 20/9, Site IV, Sahibabad Industrial Area, SAHIBABAD 201010

Telephone
8-77 00 32

Regional Offices:

Central : Manak Bhavan, 9 Bahadur Shah Zafar Marg, NEW DELHI 110002 323 76 17
*Eastern : 1/14 CIT Scheme VII M, V.I.P. Road, Maniktola, CALCUTTA 700054 337 86 62
Northern : SCO 335-336, Sector 34-A, CHANDIGARH 160022 60 38 43
Southern : C.I.T. Campus, IV Cross Road, CHENNAI 600113 235 23 15
†Western : Manakalaya, E9 Behind Marol Telephone Exchange, Andheri (East),
MUMBAI 400093 832 92 95

Branch Offices:

'Pushpak', Nurmohamed Shaikh Marg, Khanpur, AHMEDABAD 380001 550 13 48
‡Peenya Industrial Area, 1st Stage, Bangalore - Tumkur Road,
BANGALORE 560058 839 49 55
Gangotri Complex, 5th Floor, Bhadbhada Road, T. T. Nagar, BHOPAL 462003 55 40 21
Plot No. 62-63, Unit VI, Ganga Nagar, BHUBANESHWAR 751001 40 36 27
Kalaikathir Buildings, 670 Avinashi Road, COIMBATORE 641037 21 01 41
Plot No. 43, Sector 16 A, Mathura Road, FARIDABAD 121001 8-28 88 01
Savitri Complex, 116 G. T. Road, GHAZIABAD 201001 8-71 19 96
53/5 Ward No. 29, R. G. Barua Road, 5th By-lane, GUWAHATI 781003 54 11 37
5-8-58C, L. N. Gupta Marg, Nampally Station Road, HYDERABAD 500001 20 10 83
E-52, Chitaranjan Marg, C-Scheme, JAIPUR 302001 37 29 25
117/418 B, Sarvodaya Nagar, KANPUR 208005 21 68 76
Seth Bhawan, 2nd Floor, Behind Leela Cinema, Naval Kishore Road,
LUCKNOW 226001 23 89 23
Pattiputra Industrial Estate, PATNA 800013 26 23 05
T. C. No. 14/1421, University P. O. Palayam,
THIRUVANANTHAPURAM 695034 6 21 17
NIT Building, Second Floor, Gokulpat Market, NAGPUR 440010 52 51 71
Institution of Engineers (India) Building, 1332 Shivaji Nagar, PUNE 411005 32 36 35

*Sales Office is at 5 Chowringhee Approach, P. O. Princep Street,
CALCUTTA 700072

27 10 85

†Sales Office is at Novelty Chambers, Grant Road, MUMBAI 400007

309 65 28

‡Sales Office is at 'F' Block, Unity Building, Narashimaraja Square,
BANGALORE 560002

222 39 71