

IS : 10079 - 1982

Indian Standard

Reaffirmed 1989

SPECIFICATION FOR
CYLINDRICAL METAL MEASURES
FOR USE IN TESTS OF AGGREGATES
AND CONCRETE

UDC 666.972 : 389.1 : [669] : 620.1

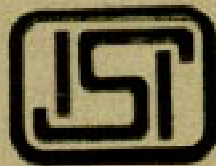

© Copyright 1982

INDIAN STANDARDS INSTITUTION
MANAK BHAVAN, 9 BAHADUR SHAH ZAFAR MARG
NEW DELHI 110002

Indian Standard
**SPECIFICATION FOR
 CYLINDRICAL METAL MEASURES
 FOR USE IN TESTS OF AGGREGATES
 AND CONCRETE**

Cement and Concrete Sectional Committee, BDC 2

Chairman

DR H. C. VISVESVARAYA

Representing

Cement Research Institute of India, New Delhi

Members

ADDITIONAL DIRECTOR, STANDARDS (B & S)	Research, Designs & Standards Organization (Ministry of Railways), Lucknow
DEPUTY DIRECTOR, STANDARDS (B & S) (<i>Alternate</i>)	
SHRI K. P. BANERJEE	Larsen & Toubro Ltd, Bombay
SHRI HARISH N. MALANI (<i>Alternate</i>)	
SHRI S. K. BANERJEE	National Test House, Calcutta
SHRI R. N. BANSAL	Beas Designs Organization, Nangal Township
SHRI T. C. GARG (<i>Alternate</i>)	
SHRI R. V. CHALAPATHI RAO	Geological Survey of India, Calcutta
SHRI S. ROY (<i>Alternate</i>)	
CHIEF ENGINEER (DESIGNS)	Central Public Works Department, New Delhi
EXECUTIVE ENGINEER (DESIGNS) III (<i>Alternate</i>)	
CHIEF ENGINEER (PROJECTS)	Irrigation Department, Government of Punjab, Chandigarh
DIRECTOR, IPRI (<i>Alternate</i>)	
DIRECTOR (CSMRS)	Central Soil and Materials Research Station, New Delhi
DEPUTY DIRECTOR (CSMRS) (<i>Alternate</i>)	
SHRI T. A. E. D'SA	The Concrete Association of India, Bombay
SHRI N. C. DUGGAL (<i>Alternate</i>)	
SHRI A. K. GUPTA	Hyderabad Asbestos Cement Products Ltd, Hyderabad
SHRI V. K. GUPTA	Engineer-in-Chief's Branch, Army Headquarters, New Delhi
SHRI S. N. PANDE (<i>Alternate</i>)	

(*Continued on page 2*)© *Copyright* 1982

INDIAN STANDARDS INSTITUTION

This publication is protected under the *Indian Copyright Act* (XIV of 1957) and reproduction in whole or in part by any means except with written permission of the publisher shall be deemed to be an infringement of copyright under the said Act.

IS : 10079 - 1982

(Continued from page 1)

<i>Members</i>	<i>Representing</i>
DR R. R. HATTIANGADI SHRI P. J. JAGUS (<i>Alternate</i>)	The Associated Cement Companies Ltd, Bombay
DR IQBAL ALI SHRI S. R. KULKARNI SHRI S. K. LAHA SHRI B. T. UNWALLA (<i>Alternate</i>)	Engineering Research Laboratories, Hyderabad M. N. Dastur & Co Pvt Ltd, Calcutta The Institution of Engineers (India), Calcutta
DR MOHAN RAI	Central Building Research Institute (CSIR), Roorkee
DR S. S. REHSI (<i>Alternate</i>) SHRI K. K. NAMBIAR	In personal capacity ('Ramanalaya' 11 First Crescent Park Road, Gandhinagar, Adyar, Madras)
SHRI H. S. PASRICHA SHRI C. S. MISHRA (<i>Alternate</i>) SHRI Y. R. PHULL	Hindustan Prefab Ltd, New Delhi Central Road Research Institute (CSIR), New Delhi
SHRI M. R. CHATTERJEE (<i>Alternate I</i>) SHRI K. L. SETHI (<i>Alternate II</i>) DR M. RAMAIAH	Structural Engineering Research Centre (CSIR), Roorkee
DR N. S. BHAL (<i>Alternate</i>) SHRI G. RAMDAS	Directorate General of Supplies and Disposals, New Delhi
DR A. V. R. RAO SHRI J. SEN GUPTA (<i>Alternate</i>) SHRI T. N. S. RAO SHRI S. R. PINHEIRO (<i>Alternate</i>)	National Buildings Organization, New Delhi Gammon India Ltd, Bombay
REPRESENTATIVE SHRI ARJUN RIJHSINGHANI SHRI K. VIJITHAL RAO (<i>Alternate</i>)	Indian Roads Congress, New Delhi Cement Corporation of India Ltd, New Delhi
SECRETARY DEPUTY SECRETARY (I) (<i>Alternate</i>) SHRI N. SIVAGURU	Central Board of Irrigation and Power, New Delhi Roads Wing, Ministry of Shipping and Transport, New Delhi
SHRI R. L. KAPOOR (<i>Alternate</i>) SHRI K. A. SUBRAMANIAM SHRI P. S. RAMACHANDRAN (<i>Alternate</i>)	The India Cements Ltd, Madras
SUPERINTENDING ENGINEER (DESIGNS) EXECUTIVE ENGINEER (SM & R DIVISION) (<i>Alternate</i>)	Public Works Department, Government of Tamil Nadu, Madras
SHRI L. SWAROOP SHRI A. V. RAMANA (<i>Alternate</i>) SHRI G. RAMAN, Director (Civ Engg)	Dalmia Cement (Bharat) Ltd, New Delhi Director General, ISI (<i>Ex-officio Member</i>)

Secretary

SHRI M. N. NEELAKANDHAN
Assistant Director (Civ Engg), ISI

(Continued on page 11)

Indian Standard
SPECIFICATION FOR
CYLINDRICAL METAL MEASURES
FOR USE IN TESTS OF AGGREGATES
AND CONCRETE

0. FOREWORD

0.1 This Indian Standard was adopted by the Indian Standards Institution on 28 January 1982, after the draft finalized by the Cement and Concrete Sectional Committee had been approved by the Civil Engineering Division Council.

0.2 The Indian Standards Institution has already published a series of standards on methods of testing cement and concrete. It has been recognized that reproducible and repeatable test results can be obtained only with standard testing equipment capable of giving the desired level of accuracy. The Sectional Committee has, therefore, decided to bring out a series of specifications covering the requirements of equipment used for testing cement and concrete, to encourage their development and manufacture in the country.

0.3 Accordingly, this standard has been prepared to cover requirements of the cylindrical metal measures used in testing aggregates and concrete. The relevant methods of tests wherein use of these measures is called for are covered in IS : 1199-1959* and IS : 2386 (Part III)-1963†.

0.4 In the formulation of this standard, due weightage has been given to international co-ordination among the standards and practices prevailing in different countries in addition to relating it to the practices in the field in this country.

0.5 For the purpose of deciding whether a particular requirement of this standard is complied with, the final value, observed or calculated, expressing the result of a test or analysis, shall be rounded off in accordance with IS : 2-1960‡. The number of significant places retained in the rounded off value should be the same as that of the specified value in this standard.

*Methods of sampling and analysis of concrete.

†Methods of test for aggregates for concrete : Part III Specific gravity, density, voids, absorption and bulking.

‡Rules for rounding off numerical values (revised).

1. SCOPE

1.1 This standard covers the requirements of cylindrical metal measures used in tests for determining the following:

- a) Bulk density and voids of aggregates for concrete, and
- b) Weight per cubic metre, yield, cement factor and air content (gravimetric) of freshly mixed concrete.

2. CYLINDRICAL METAL MEASURES

2.1 Cylindrical metal measures shall be of capacities 3, 10, 15, 20 and 30 litres.

3. MATERIAL

3.1 The material of construction of cylindrical metal measures shall be mild steel.

NOTE — Use of mild steel conforming to IS : 226-1975* is recommended.

4. DIMENSIONS

4.1 Dimensions with tolerances for cylindrical metal measures specified in 2.1 shall be as given in Table 1. Where tolerances are not specifically mentioned, dimensions shall be considered nominal.

NOTE — Allowable deviations for nominal dimensions shall be as laid down for coarse class of deviation in IS : 2102-1969†.

TABLE 1. DIMENSIONS OF CYLINDRICAL METAL MEASURES

SL No.	CAPACITY litres	INSIDE DIAMETER, A* mm	INSIDE HEIGHT, B*	THICKNESS OF METAL (Min), mm	
				Wall, C*	Bottom, D*
(1)	(2)	(3)	(4)	(5)	(6)
i)	3 ± .03	150 ± 1.5	To be	2.5	4.5
ii)	10 ± .10	250 ± 2	adjusted	2.5	4.5
iii)	15 ± .15	250 ± 2	to get	2.5	4.4
iv)	20 ± .20	350 ± 2	the required	2.5	4.5
v)	30 ± .30	350 ± 2	capacity	2.5	4.5

*The symbols correspond to dimensions indicated in Fig. 1.

*Specification for structural steel (standard quality) (*fifth revision*).

†Allowable deviations for dimensions without specified tolerances (*first revision*).

5. CONSTRUCTION

5.1 Cylindrical metal measures shall be constructed as shown in Fig. 1 and Fig. 2. The measures shall be water-tight, preferably machined to accurate dimensions on the inside and sufficiently rigid to retain their form under rough usage. The 15, 20 and 30 litre capacity measures shall be reinforced around the top with a metal band to provide an overall wall thickness of not less than 5 mm in the upper 40 mm. The measures may be provided with handles.

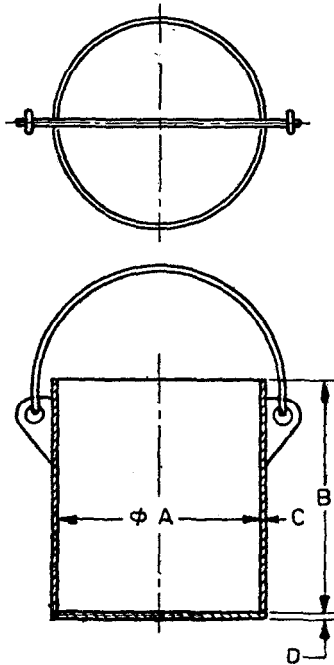

FIG. 1 TYPICAL CYLINDRICAL MEASURE OF 3 AND 10 LITRE CAPACITY

6. ACCESSORIES

6.1 Tamping Rod

6.1.1 The tamping rod shall be 16 ± 0.5 mm in dia and 600 ± 2 mm long with a rounded working end and shall be made of mild steel.

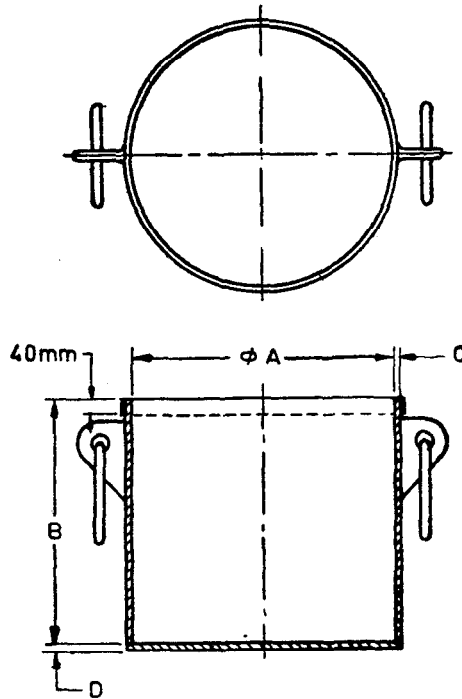

FIG. 2 TYPICAL CYLINDRICAL MEASURE OF 15, 20 AND 30 LITRE CAPACITY

6.2 Tamping Bar

6.2.1 The tamping bar shall be of square cross-section with tamping face 25 ± 0.5 mm square and 400 ± 2 mm long and weighing 2 kg and shall be made of mild steel and provided with a handle.

7. MARKING

7.1 The following information shall be clearly and indelibly marked on each of the cylindrical metal measures:

- a) Name of the manufacturer or his registered trade-mark or both, and
- b) Date of manufacture.

7.2 Cylindrical metal measures may also be marked with the ISI Certification Mark.

NOTE — The use of the ISI Certification Mark is governed by the provisions of the Indian Standards Institution (Certification Marks) Act and the Rules and Regulations made thereunder. The ISI Mark on products covered by an Indian Standard conveys the assurance that they have been produced to comply with the requirements of that standard under a well-defined system of inspection, testing and quality control which is devised and supervised by ISI and operated by the producer. ISI marked products are also continuously checked by ISI for conformity to that standard as a further safeguard. Details of conditions under which a licence for the use of the ISI Certification Mark may be granted to manufacturers or processors, may be obtained from the Indian Standards Institution.

IS : 10079 - 1982

(Continued from page 2)

Instruments for Cement and Concrete Testing Subcommittee, BDC 2 : 10

Convener

DR IQBAL ALI

Members

SHRI P. D. AGARWAL

DR T. N. CHOJER (*Alternate*)

PROF B. M. AHUJA

SHRI T. P. EKAMBARAM

SHRI H. K. GUHA

DEPUTY SECRETARY (*Alternate*)

SHRI P. J. JAGUS

SHRI D. A. WADIA (*Alternate*)

SHRI M. R. JOSHI

SHRI Y. P. PATHAK (*Alternate*)

SHRI E. K. RAMACHANDRAN

SHRI S. K. BANERJEE (*Alternate*)

PROF C. K. RAMESH

DR R. S. AYYAR (*Alternate*)

SHRI M. V. RANGA RAO

DR K. C. NARANG (*Alternate*)

DR S. S. REHSI

SHRI J. P. KAUSHISH (*Alternate*)

SHRI A. V. S. R. SASTRI

SHRI SUBHASH SHARMA (*Alternate*)

SHRI K. L. SETHI

SHRI M. L. BHATIA (*Alternate*)

Representing

Engineering Research Laboratories, Hyderabad

Public Works Department, Government of Uttar Pradesh, Lucknow

Indian Institute of Technology, New Delhi
Highways Research Station, Madras
All India Instruments Manufacturers and Dealers Association, Bombay

The Associated Cement Companies Ltd, Bombay

Research & Development Organization (Ministry of Defence), Pune

National Test House, Calcutta

Indian Institute of Technology, Bombay

Cement Research Institute of India, New Delhi

Central Building Research Institute (CSIR), Roorkee

Associated Instrument Manufacturers (India) Private Ltd, New Delhi

Central Road Research Institute (CSIR), New Delhi