

IS : 2386 ( Part IV ) - 1963  
( Reaffirmed 1990 )

*Indian Standard*

METHODS OF TEST FOR  
AGGREGATES FOR CONCRETE

**PART IV MECHANICAL PROPERTIES**

---

Tenth Reprint MARCH 1997  
( Incorporating Amendment No. 1 )

UDC 691.322 : 620.17

© *Copyright* 1972

**BUREAU OF INDIAN STANDARDS**  
MANAK BHAVAN, 9 BAHADUR SHAH ZAFAR MARG  
NEW DELHI 110002

# *Indian Standard*

## METHODS OF TEST FOR AGGREGATES FOR CONCRETE

### PART IV MECHANICAL PROPERTIES

Cement and Concrete Sectional Committee, BDC 2

*Chairman*  
SHRI K. K. NAMBIAR

*Representing*  
The Concrete Association of India, Bombay

*Members*

SHRI K. V. THADANEY (*Alternate to*  
Shri K. K. Nambiar)

SHRI K. F. ANTIA  
SHRI P. S. BHATNAGAR  
DR I. C. DOS M. PAIS CUDDOU

M. N. Dastur & Co Private Ltd, Calcutta  
Bhakra Dam Designs Directorate, New Delhi  
Central Water & Power Commission (Ministry of Irrigation  
& Power)

SHRI Y. K. MURTHY (*Alternate*)

SHRI N. D. DAFTARY  
SHRI N. G. DEWAN

Khira Steel Works Private Ltd, Bombay  
Central Public Works Department

SUPERINTENDING ENGINEER, 2ND CIRCLE (*Alternate*)

DR R. R. HATTIANGADI

The Associated Cement Companies Ltd, Bombay

SHRI V. N. PAI (*Alternate*)

SHRI P. C. HAZRA

Geological Survey of India, Calcutta

JOINT DIRECTOR STANDARDS (B & S)

Research, Designs & Standards Organization (Ministry of  
Railways)

ASSISTANT DIRECTOR STANDARDS (B & S) (*Alternate*)

SHRI S. B. JOSHI

S. B. Joshi & Co Private Ltd, Bombay

SHRI M. M. LAL

U. P. Government Cement Factory, Churk

SHRI B. N. MAJUMDAR

Directorate General of Supplies & Disposals (Ministry of  
Economic & Defence Co-ordination)

SHRI P. L. DAS (*Alternate*)

PROF S. R. MEHRA

Central Road Research Institute (CSIR), New Delhi

SHRI N. H. MOHILB

The Concrete Association of India, Bombay

SHRI S. N. MUKERJI

Government Test House, Calcutta

SHRI N. C. SEN GUPTA (*Alternate*)

SHRI ERACH A. NADIRSHAH

Institution of Engineers (India), Calcutta

SHRI C. B. PATEL

National Buildings Organization (Ministry of Works, Housing  
& Rehabilitation)

SHRI RABINDER SINGH (*Alternate*)

PROF G. S. RAMASWAMY

Central Building Research Institute (CSIR), Roorkee

SHRI K. SIVA PRASAD (*Alternate*)

SHRI T. N. S. RAO

Gammon India Ltd, Bombay

SHRI S. R. PINHEIRO (*Alternate*)

(Continued on page 2)

**BUREAU OF INDIAN STANDARDS**  
MANAK BHAVAN, 9 BAHADUR SHAH ZAFAR MARG  
NEW DELHI 110002

# IS : 2386 (Part IV) - 1963

(Continued from page 1)

## Members

### REPRESENTATIVE

SHRI NIHAR CHANDRA ROY  
SECRETARY

BRIG G. S. SIHOTA

SHRI R. S. MEHANDRU (*Alternate*)

DR. BI. SUBBARAJU

SHRI J. M. TREHAN

SHRI N. H. KESWANI (*Alternate*)

DR. H. C. VISVESVARAYA,

Deputy Director (Bldg)

## Representing

Martin Burn Ltd, Calcutta

Dalmia Cement (Bharat) Ltd, Calcutta

Central Board of Irrigation & Power (Ministry of Irrigation  
& Power)

Engineer-in-Chief's Branch, Army Headquarters

Indian Roads Congress, New Delhi

Roads Wing, Ministry of Transport & Communications

Director, ISI (*Ex-officio Member*)

## Secretary

SHRI A. PRITHVI RAJ

Extra Assistant Director (Bldg), ISI

## Concrete Subcommittee, BDC 2 : 2

### Convener

SHRI S. B. JOSHI

S. B. Joshi & Co Private Ltd, Bombay

### Members

ASSISTANT DIRECTOR STANDARDS (B & S)

Research, Designs & Standards Organization (Ministry of  
Railways)

SHRI N. H. BHAOGWANANI

Engineer-in-Chief's Branch, Army Headquarters

DR I. C. DOS M. PAIS CUDDOU

Central Water & Power Commission (Ministry of Irrigation  
& Power)

SHRI Y. K. MURTHY (*Alternate*)

SHRI P. L. DAS

Directorate General of Supplies & Disposals (Ministry of  
Economic & Defence Co-ordination)

SHRI B. N. MAJUMDAR (*Alternate*)

DIRECTOR

Engineering Research Laboratory, Hyderabad

SHRI V. N. GUNAJI

Maharashtra Public Works Department

SHRI M. A. HAFEEZ

National Buildings Organization (Ministry of Works, Housing  
& Rehabilitation)

SHRI B. S. SHIVAMURTHY (*Alternate*)

SHRI C. L. HANDA

Central Water & Power Commission (Ministry of Irrigation  
& Power)

SHRI P. C. HAZRA

Geological Survey of India, Calcutta

SHRI K. K. NAMBIAR

The Concrete Association of India, Bombay

SHRI C. L. N. IYENGER (*Alternate*)

DR. M. L. PURI

Central Road Research Institute (CSIR), New Delhi

PROF. G. S. RAMASWAMY

Central Building Research Institute (CSIR), Roorkee

SHRI K. SIVA PRASAD (*Alternate*)

SHRI T. N. S. RAO

Gammon India Ltd, Bombay

SHRI S. R. PINHEIRO (*Alternate*)

SUPERINTENDING ENGINEER, 2ND CIRCLE

Central Public Works Department

SHRI O. P. GOEL (*Alternate*)

SHRI J. M. TREHAN

Roads Wing, Ministry of Transport & Communications

SHRI R. P. SIKKA (*Alternate*)

SHRI H. T. YAN

Braithwaite Burn & Jessop Construction Co Ltd, Calcutta

*Indian Standard*METHODS OF TEST FOR  
AGGREGATES FOR CONCRETE

## PART IV MECHANICAL PROPERTIES

**0. FOREWORD**

**0.1** This Indian Standard (Part IV) was adopted by the Indian Standards Institution on 24 September 1963, after the draft finalized by the Cement and Concrete Sectional Committee had been approved by the Building Division Council.

**0.2** One of the major contributing factors to the quality of concrete is the quality of aggregates used therein. The test methods given in this standard are intended to assist in assessing the quality of aggregates. In a given situation, for a particular aggregate, it may not be necessary to assess all the qualities and therefore it is necessary to determine beforehand the purpose for which a concrete is being used and the qualities of the aggregate which require to be assessed. Accordingly, the relevant test methods may be chosen from amongst the various tests covered in this standard. For the convenience of the users, the test methods are grouped into the following eight parts of Indian Standard Methods of Test for Aggregates for Concrete (IS : 2386-1963):

- Part I Particle Size and Shape
- Part II Estimation of Deleterious Materials and Organic Impurities
- Part III Specific Gravity, Density, Voids, Absorption and Bulking
- Part IV Mechanical Properties
- Part V Soundness
- Part VI Measuring Mortar Making Properties of Fine Aggregate
- Part VII Alkali Aggregate Reactivity
- Part VIII Petrographic Examination

**0.3** The Sectional Committee responsible for the preparation of this standard has taken into consideration the views of concrete specialists, testing authorities, consumers and technologists and has related the standard to the practices followed in this country. Further, the need for international co-ordination among standards prevailing in different countries of the world has also been recognized. These considerations led the Sectional Committee

## IS : 2386 (Part IV) - 1963

to derive assistance from the published standards and publications of the following organizations:

British Standards Institution

American Society for Testing and Materials

**0.4** Wherever a reference to any Indian Standard appears in these methods, it shall be taken as a reference to its latest version.

**0.5** For the purpose of deciding whether a particular requirement of this standard is complied with, the final value, observed or calculated, expressing the result of a test or analysis, shall be rounded off in accordance with IS : 2-1960 Rules for Rounding Off Numerical Values (*Revised*). The number of significant places retained in the rounded off value should be the same as that of the specified value in this standard.

**0.6** This standard is intended chiefly to cover the technical provisions relating to testing of aggregates for concrete, and it does not include all the necessary provisions of a contract.

---

## 1. SCOPE

**1.1** This standard (Part IV) covers the following tests for aggregates for concrete:

- a) Determination of Aggregate Crushing Value,
- b) Determination of the 10 percent Fines Value,
- c) Determination of Aggregate Impact Value,
- d) Determination of Aggregate Abrasion Value,
- e) Determination of the Polished Stone Value, and
- f) Determination of Crushing Strength.

## 2. DETERMINATION OF AGGREGATE CRUSHING VALUE

**2.1 Object** — This method of test covers the procedure for determining the aggregate crushing value of coarse aggregate.

**NOTE 1** — The 'aggregate crushing value' gives a relative measure of the resistance of an aggregate to crushing under a gradually applied compressive load. With aggregate of 'aggregate crushing value' 30 or higher, the result may be anomalous, and in such cases the 'ten percent fines value' should be determined instead.

**NOTE 2** — The standard aggregate crushing test shall be made on aggregate passing a 12.5-mm IS Sieve and retained on a 10-mm IS Sieve. If required, or if the standard size is not available, other sizes up to 25 mm may be tested but owing to the non-homogeneity of aggregates the results will not be comparable with those obtained in the standard (*see* Note 1 under 2.6). Smaller sizes may also be tested (*see* Note 2 under 2.6).

**2.2 Apparatus** — The apparatus for the standard test shall consist of the following:

- a) A 15-cm diameter open-ended steel cylinder, with plunger and base-plate, of the general form and dimensions shown in Fig. 1. The surfaces in contact with the aggregate shall be machined and case-hardened or otherwise treated so as to have a diamond (VH) pyramid hardness number of not less than 650 VH.
- b) A straight metal tamping rod of circular cross-section 16 mm in diameter and 45 to 60 cm long, rounded at one end.
- c) A balance of capacity 3 kg, readable and accurate to one gram.
- d) IS Sieves of sizes 12.5, 10 and 2.36 mm.
- e) A compression testing machine capable of applying a load of 40 tonnes and which can be operated to give a uniform rate of loading so that the maximum load is reached in 10 minutes. The machine may be used with or without a spherical seating.
- f) For measuring the sample, cylindrical metal measure of sufficient rigidity to retain its form under rough usage and of the following internal dimensions:

Diameter	11.5 cm
Height	18.0 cm

**2.3 Preparation of Test Sample** — The material for the standard test shall consist of aggregate passing a 12.5-mm IS Sieve and retained on a 10-mm IS Sieve, and shall be thoroughly separated on these sieves before testing. For other sizes, the material shall be separated on the appropriate sieves given in Table I.

**TABLE I DETAILS OF AGGREGATE CRUSHING TEST FOR NON-STANDARD SIZES OF AGGREGATE**

(Clauses 2.3 and 2.4.2)

NOMINAL SIZES (IS SIEVES)		DIAMETER OF CYLINDER TO BE USED	SIZE OF IS SIEVE FOR SEPARATING FINES
Passing through	Retained on		
mm	mm	cm	
25	20	15.0	4.75 mm
20	12.5	15.0	3.35 mm
10	6.3	15.0 or 7.5	1.70 mm
6.3	4.75	15.0 or 7.5	1.18 mm
4.75	3.35	15.0 or 7.5	850 microns
3.35	2.36	15.0 or 7.5	600 microns

NOTE — About 6.5 kg of natural aggregate is required to provide the two test samples for the 15-cm cylinder, or about 1 kg for the 7.5-cm cylinder.

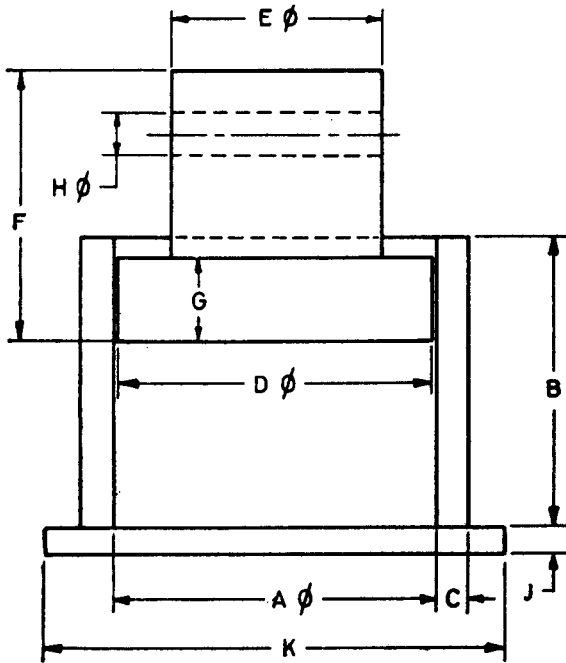

KEY TO DIMENSIONS			
LETTER	DIMENSIONS FOR	150-mm CYLINDER	75-mm CYLINDER
A B C	<i>Cylinder</i>	mm	mm
	Internal diameter	152.0 ± 0.5	77.0 ± 0.5
	Height	130 to 140	70 to 80
C	Wall thickness	≤ 16	≤ 8
D E F	<i>Plunger</i>		
	Diameter of piston	150 ± 0.5	75.0 ± 0.5
	Diameter of stem	100 to 150	50 to 75
F	Height	100 to 115	65 to 75
G	Depth of piston	≤ 25	≤ 20
H	Diameter of hole (nominal)	20	10
J K	<i>Base-Plate</i>		
	Thickness (nominal)	6.3	6.3
K	Side length of square	200 to 230	110 to 115

FIG. 1 PRINCIPAL DIMENSIONS OF APPARATUS FOR AGGREGATE CRUSHING TEST

**2.3.1** The aggregate shall be tested in a surface-dry condition. If dried by heating, the period of drying shall not exceed four hours, the temperature shall be 100 to 110°C and the aggregate shall be cooled to room temperature before testing.

**2.3.2** The quantity of aggregate shall be such that the depth of material in the cylinder, after tamping as described in 2.3.3, shall be 10 cm.

**2.3.3** The appropriate quantity may be found conveniently by filling the cylindrical measure in three layers of approximately equal depth, each layer being tamped 25 times with the rounded end of the tamping rod and finally levelled off, using the tamping rod as a straight-edge.

**2.3.4** The weight of material comprising the test sample shall be determined (Weight *A*) and the same weight of sample shall be taken for the repeat test.

**2.4 Test Procedure** — The cylinder of the test apparatus shall be put in position on the base-plate and the test sample added in thirds, each third being subjected to 25 strokes from the tamping rod. The surface of the aggregate shall be carefully levelled and the plunger inserted so that it rests horizontally on this surface, care being taken to ensure that the plunger does not jam in the cylinder.

**2.4.1** The apparatus, with the test sample and plunger in position, shall then be placed between the platens of the testing machine and loaded at as uniform a rate as possible so that the total load is reached in 10 minutes. The total load shall be 40 tonnes.

**2.4.2** The load shall be released and the whole of the material removed from the cylinder and sieved on a 2.36-mm IS Sieve for the standard test, or the appropriate sieve given in Table I. The fraction passing the sieve shall be weighed (Weight *B*).

In all of these operations, care shall be taken to avoid loss of the fines. Two tests shall be made.

**2.5 Calculation** — The ratio of the weight of fines formed to the total sample weight in each test shall be expressed as a percentage, the result being recorded to the first decimal place:

$$\text{Aggregate crushing value} = \frac{B}{A} \times 100$$

where

*B* = weight of fraction passing the appropriate sieve, and

*A* = weight of surface-dry sample.

**2.6 Reporting of Results** — The mean of the two results shall be reported



to the nearest whole number as the 'aggregate crushing value' of the size of material tested, which shall be stated.

*NOTE 1 — Aggregate larger than 12.5 mm* — In general, the larger sizes of aggregate will give a higher aggregate crushing value, but the relationship between the values obtained with different sizes will vary from one aggregate to another. Particular care shall be taken with larger sizes of aggregate to ensure that the plunger does not jam in the cylinder. However, for such aggregate, a 7.5-cm diameter cylinder may be used, and this has been found to give slightly higher results than the standard cylinder, so that the errors are compensating.

*NOTE 2 — Aggregate smaller than 10 mm* — In general, the smaller sizes of aggregate will give a lower aggregate crushing value, but the relationship between the values obtained with different sizes will vary from one aggregate to another.

For testing aggregate smaller than 10 mm:

- a) The form and dimensions of the 7.5-cm cylinder shall be as shown in Fig. 1 and the surfaces shall be as for the standard cylinder.
- b) The tamping rod shall be 8 mm in diameter and 30 cm long, rounded at one end.
- c) The balance shall be of capacity 500 g, readable and accurate to 0.2 g.
- d) The IS Sieves shall be as given in Table I.
- e) The compression testing machine shall be capable of applying a load of 10 tonnes uniformly in 10 minutes.
- f) The metal measure shall be 6 cm in diameter and 9 cm in height.
- g) The depth of material in the 7.5-cm cylinder shall be 5 cm after tamping.
- h) The total load applied in 10 minutes shall be 10 tonnes.

Otherwise, the provisions of the standard test, as set out in 2.2 to 2.6 shall apply.

### **3. DETERMINATION OF TEN PERCENT FINES VALUE**

**3.1 Object** — This method of test covers the procedure for determining the 'ten percent fines' value of coarse aggregates.

*NOTE* — The 'ten percent fines' value gives a measure of the resistance of an aggregate to crushing, that is, applicable to all aggregates.

**3.2 Apparatus** — The apparatus for the standard test shall consist of the following:

- a) A 15-cm diameter open-ended steel cylinder, with plunger and base-plate, of the general form and dimensions shown in Fig. 1. The surfaces in contact with the aggregate shall be machined and case-hardened or otherwise treated so as to have a diamond (VH) pyramid hardness number of not less than 650 VH.

- b) A straight metal tamping rod of circular cross-section 16 mm in diameter and 45 to 60 cm long, rounded at one end.
- c) A balance of capacity 3 kg, readable and accurate to one gram.
- d) The IS Sieves of sizes 12.5, 10 and 2.36 mm.
- e) A compression testing machine capable of applying a load of 50 tonnes and which can be operated to give a uniform rate of loading so that the maximum load in any test is reached in 10 minutes. This load may vary from 0.5 to 50 tonnes.
- f) For measuring the sample, a cylindrical metal measure of sufficient rigidity to retain its form under rough usage and of the following internal dimensions:

Diameter 11.5 cm

Height 18.0 cm

- g) Means of measuring the reduction in the distance between the platens of the testing machine to the nearest one millimetre during the test (for example, a dial gauge).

**3.3 Preparation of Test Sample** — The material for the test shall consist of aggregate passing a 12.5-mm IS Sieve and retained on a 10-mm IS Sieve and shall be thoroughly separated on these sieves before testing.

**3.3.1** The aggregate shall be tested in a surface-dry condition. If dried by heating, the period of drying shall not exceed four hours, the temperature shall be 100 to 110°C and the aggregate shall be cooled to room temperature before testing.

**3.3.2** The quantity of aggregate shall be such that the depth of material in the cylinder, after tamping as described in **3.3.2.1**, shall be 10 cm.

**3.3.2.1** The appropriate quantity may be found conveniently by filling the cylindrical measure in three layers of approximately equal depth, each layer being tamped 25 times with the tamping rod and finally levelled off, using the tamping rod as a straight-edge, care being taken in the case of weaker materials not to break the particles.

**3.3.3** The weight of material comprising the test sample shall be determined (Weight *A*) and the same weight of sample shall be taken for the repeat test.

NOTE — About 6.5 kg of natural aggregate is required to provide the two test samples. Less of light-weight aggregate is required.

**3.4 Test Procedure** — The cylinder of the test apparatus shall be put in position on the base-plate and the test sample added in thirds, each third being subjected to 25 strokes from the tamping rod, care being taken in the case of weak materials not to break the particles. The surface of the aggregate shall be carefully levelled and the plunger inserted so that it

rests horizontally on this surface, care being taken to ensure that the plunger does not jam in the cylinder.

**3.4.1** The apparatus, with the test sample and plunger in position, shall then be placed in the compression testing machine. The load shall be applied at a uniform rate so as to cause a total penetration of the plunger in 10 minutes of about:

15.0 mm for rounded or partially rounded aggregates (for example, uncrushed gravels),

20.0 mm for normal crushed aggregates, and

24.0 mm for honeycombed aggregates (for example, expanded shales and slags).

These figures may be varied according to the extent of the rounding or honeycombing.

**3.4.2** After reaching the required maximum penetration, the load shall be released and the whole of the material removed from the cylinder and sieved on a 2.36-mm IS Sieve. The fines passing the sieve shall be weighed, and this weight expressed as a percentage of the weight of the test sample. Normally, this percentage will fall within the range 7.5 to 12.5, but if it does not, a further test shall be made at a load adjusted as seems appropriate to bring the percentage fines within the range of 7.5 to 12.5.

NOTE — The formula given in 3.5 may be used for calculating the load required.

**3.4.3** A repeat test shall be made at the load that gives a percentage fines within the range 7.5 to 12.5.

**3.5 Calculations** — The mean percentage fines from the two tests at this load shall be used in the following formula to calculate the load required to give 10 percent fines:

$$\text{Load required for 10 percent fines} = \frac{14 \times x}{y + 4}$$

where

$x$  = load in tonnes, and

$y$  = mean percentage fines from two tests at  $x$  tonnes load.

**3.6 Reporting of Results** — The load required to produce 10 percent fines shall be reported to the nearest whole number for loads of 10 tonnes or more, the nearest 0.5 tonne for loads of less than 10 tonnes.

#### 4. DETERMINATION OF AGGREGATE IMPACT VALUE

**4.1 Object** — This method of test covers the procedure for determining the aggregate impact value of coarse aggregate.

NOTE — The 'aggregate impact value' gives a relative measure of the resistance of an aggregate to sudden shock or impact, which in some aggregates differs from its resistance to a slow compressive load.

**4.2 Apparatus** — The apparatus shall consist of the following:

- a) An impact testing machine of the general form shown in Fig. 2 and complying with the following:
  - 1) Total weight not more than 60 kg nor less than 45 kg.
  - 2) The machine shall have a metal base weighing between 22 and 30 kg with a plane lower surface of not less than 30 cm diameter, and shall be supported on a level and plane concrete or stone block or floor at least 45 cm thick. The machine shall be prevented from rocking either by fixing it to the block or floor or by supporting it on a level and plane metal plate cast into the surface of the block or floor.
  - 3) A cylindrical steel cup of internal dimensions:
 

Diameter	102 mm
Depth	50 mm

 and not less than 6.3 mm thick with its inner surface case-hardened, that can be rigidly fastened at the centre of the base and easily removed for emptying.
  - 4) A metal tup or hammer weighing 13.5 to 14.0 kg, the lower end of which shall be cylindrical in shape, 100.0 mm in diameter and 5 cm long, with a 2-mm chamfer at the lower edge, and case-hardened. The hammer shall slide freely between vertical guides so arranged that the lower (cylindrical) part of the hammer is above and concentric with the cup.
  - 5) Means for raising the hammer and allowing it to fall freely between the vertical guides from a height of  $380 \pm 5.0$  mm on to the test sample in the cup, and means for adjusting the height of fall within 5 mm.
  - 6) Means for supporting the hammer whilst fastening or removing the cup.

NOTE — Some means for automatically recording the number of blows is desirable.

- b) *Sieves* — The IS Sieves of sizes 12.5, 10 and 2.36 mm.
- c) *Measure* — A cylindrical metal measure, tared to the nearest gram, of sufficient rigidity to retain its form under rough usage, and of the following internal dimensions:
 

Diameter	75 mm
Depth	50 mm
- d) *Tamping Rod* — A straight metal tamping rod of circular cross-section 10 mm in diameter and 230 mm long, rounded at one end.
- e) *Balance* — A balance of capacity not less than 500 g, readable and accurate to 0.1 g.
- f) *Oven* — A well-ventilated oven, thermostatically controlled to maintain a temperature of 100 to 110°C.

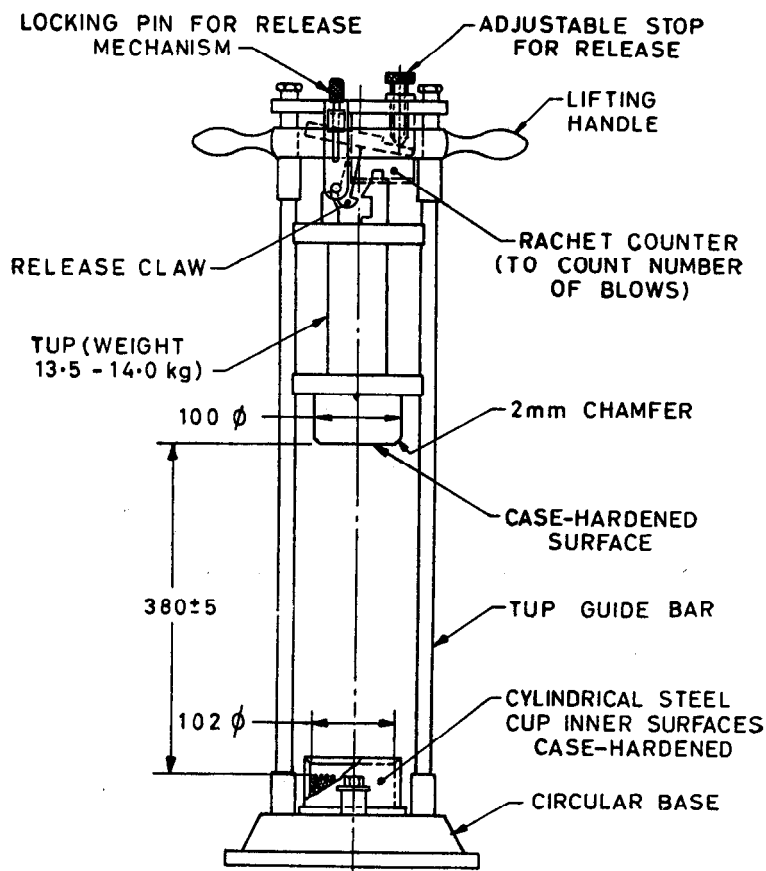

All dimensions in millimetres.

FIG. 2 AGGREGATE IMPACT TEST MACHINE

### 4.3 Preparation of the Test Sample

**4.3.1** The test sample shall consist of aggregate the whole of which passes a 12.5-mm IS Sieve and is retained on a 10-mm IS Sieve. The aggregate comprising the test sample shall be dried in an oven for a period of four hours at a temperature of 100 to 110°C and cooled.

**4.3.2** The measure shall be filled about one-third full with the aggregate and tamped with 25 strokes of the rounded end of the tamping rod.

further similar quantity of aggregate shall be added and a further tamping of 25 strokes given. The measure shall finally be filled to overflowing, tamped 25 times and the surplus aggregate struck off, using the tamping rod as a straight-edge. The net weight of aggregate in the measure shall be determined to the nearest gram (Weight *A*) and this weight of aggregate shall be used for the duplicate test on the same material.

#### 4.4 Test Procedure

**4.4.1** The impact machine shall rest without wedging or packing upon the level plate, block or floor, so that it is rigid and the hammer guide columns are vertical.

**4.4.2** The cup shall be fixed firmly in position on the base of the machine and the whole of the test sample placed in it and compacted by a single tamping of 25 strokes of the tamping rod.

**4.4.3** The hammer shall be raised until its lower face is 380 mm above the upper surface of the aggregate in the cup, and allowed to fall freely on to the aggregate. The test sample shall be subjected to a total of 15 such blows each being delivered at an interval of not less than one second.

**4.4.4** The crushed aggregate shall then be removed from the cup and the whole of it sieved on the 2.36-mm IS Sieve until no further significant amount passes in one minute. The fraction passing the sieve shall be weighed to an accuracy of 0.1 g (Weight *B*). The fraction retained on the sieve shall also be weighed (Weight *C*) and, if the total weight (*B*+*C*) is less than the initial weight (Weight *A*) by more than one gram, the result shall be discarded and a fresh test made. Two tests shall be made.

**4.5 Calculations** — The ratio of the weight of fines formed to the total sample weight in each test shall be expressed as a percentage, the result being recorded to the first decimal place:

$$\text{Aggregate impact value} = \frac{B}{A} \times 100$$

where

*B* = weight of fraction passing 2.36-mm IS Sieve, and

*A* = weight of oven-dried sample.

**4.6 Reporting of Results** — The mean of the two results shall be reported to the nearest whole number as the aggregate impact value of the tested material.

## 5. DETERMINATION OF AGGREGATE ABRASION VALUE

**5.1 Object** — This test covers the following two methods of determining the abrasion value of coarse aggregate:

- a) By the use of Deval machine (*see* 5.2), and
- b) By the use of Los Angeles machine (*see* 5.3).

NOTE — Wherever possible, method (b) should be preferred to method (a).

## 5.2 Test for Abrasion of Coarse Aggregates by the Use of Deval Machine

**5.2.1 Apparatus** — The apparatus shall consist of the following:

a) *Deval machine* — The Deval abrasion testing machine shall consist of one or more hollow cast iron cylinders closed at one end and furnished with a tightly fitting iron cover at the other. The inside diameter of the cylinders shall be 20 cm and depth 34 cm. The cylinders shall be mounted on a shaft at an angle of 30 degrees with the axis of rotation of the shaft.

b) *Sieve* — The 1.70-mm IS Sieve having square holes.

**5.2.2 Abrasive Charge** — The abrasive charge shall consist of 6 cast iron spheres or steel spheres approximately 48 mm in diameter, each weighing between 390 and 445 g.

**5.2.2.1** An abrasive charge of 6 spheres weighing  $2\,500 \pm 10$  g shall be used with each test sample.

**5.2.3 Grading** — The coarse aggregate shall be separated by sieving in accordance with the sieve analysis specified in Part I of this standard into the various sizes required for grading the test sample according to one of the gradings specified in **5.2.4**. The material thus separated into various sizes shall be washed and dried.

**5.2.4 Test Sample** — The test sample shall consist of dry coarse aggregate made up of percentages of the various sizes conforming to one of the gradings shown below. The grading used shall be that most nearly representing the coarse aggregate furnished for the work.

Grading	Passing IS Sieve	Retained on IS Sieve	Percentage of Sample
A	20-mm	12.5-mm	25
	25-mm	20-mm	25
	40-mm	25-mm	25
	50-mm	40-mm	25
B	20-mm	12.5-mm	25
	25-mm	20-mm	25
	40-mm	25-mm	50
C	20-mm	12.5-mm	50
	25-mm	20-mm	50
D	12.5-mm	4.75-mm	50
	20-mm	12.5-mm	50
E	10-mm	4.75-mm	50
	12.5-mm	10-mm	50

**5.2.4.1** The weight of the test sample shall depend upon its average specific gravity and shall be as follows:

<i>Range in Specific Gravity</i>	<i>Weight of Sample</i> g
Over 2.8	5 500
2.4 to 2.8	5 000
2.2 to 2.39	4 500
Less than 2.2	4 000

**5.2.4.2** When the coarse aggregate furnished for the work contains as much as 25 percent of material finer than 12.5 mm but is of such size that either grading A, B or C would be used for the abrasion test, a second abrasion test shall be made, using grading D, if in the opinion of the engineer, the particles less than 12.5 mm in size are not at least equal in hardness to those particles 12.5 mm or over in size.

**5.2.4.3** *Crushed gravel* — In the case of crushed gravel, the test sample shall contain crushed fragments so as to be representative of the gravel furnished for the work and shall be prepared in accordance with **5.2.3**, **5.2.4.1** and **5.2.4.2**.

NOTE — For the purpose of this test, a crushed gravel fragment may be considered as a fragment of gravel having at least one fractured face.

**5.2.5** *Procedure* — The test sample and the abrasive charge shall be placed in the Deval abrasion testing machine and the machine rotated for 10 000 revolutions at a speed of 30 to 33 rev/min. At the completion of the test, the material shall be removed from the machine and sieved on a 1.70-mm IS Sieve. The material retained on the sieve shall be washed, dried, and accurately weighed to the nearest gram.

### **5.2.6** *Calculations*

**5.2.6.1** *Percentage of wear* — The loss by abrasion shall be considered as the difference between the original weight of the test sample and the weight of the material retained on the 1.70-mm IS Sieve, expressed as percentage of the original weight of the test sample.

**5.2.6.2** *Crushed gravel* — In the case of crushed gravel, the percentage by weight of crushed fragments shall be determined, and the permissible percentage or wear which shall be calculated as follows:

$$W = \frac{AL + (100 - A)L'}{100}$$

where

$W$  = permissible percentage of wear,



$A$  = percentage of uncrushed fragments,

$L$  = maximum percentage of wear permitted by the specifications for gravel consisting entirely of uncrushed fragments,

$100 - A$  = percentage of crushed fragments, and

$L'$  = maximum percentage of wear permitted by the specifications for gravel consisting entirely of crushed fragments.

**5.2.7 Reporting of Results** — The report shall include the following:

- a) Percentage of wear,
- b) Percentage of crushed fragments in the test sample, and
- c) Weight and grading of the test sample.

### **5.3 Test for Abrasion of Coarse Aggregates by the Use of Los Angeles Machine**

**5.3.1 Apparatus** — The apparatus shall consist of the following:

- a) *Los Angeles machine* — The Los Angeles abrasion testing machine, conforming in all its essential characteristics to the design shown in Fig. 3, shall be used. The machine shall consist of a hollow steel cylinder, closed at both ends, having an inside diameter of 700 mm and an inside length of 500 mm. The cylinder shall be mounted on stub shafts attached to the ends of the cylinders but not entering it, and shall be mounted in such a manner that it may be rotated about its axis in a horizontal position. An opening in the cylinder shall be provided for the introduction of the test sample. The opening shall be closed dust-tight with a removable cover bolted in place. The cover shall be so designed as to maintain the cylindrical contour of the interior surface unless the shelf is so located that the charge will not fall on the cover, or come in contact with it during the test. A removable steel shelf, projecting radially 88 mm into the cylinder and extending its full length, shall be mounted along one element of the interior surface of the cylinder. The shelf shall be of such thickness and so mounted, by bolts or other approved means, as to be firm and rigid. The position of the shelf shall be such that the distance from the shelf to the opening, measured along the circumference of the cylinder in the direction of rotation, shall be not less than 1 250 mm.

**NOTE** — The use of the shelf of wear-resistant steel, rectangular in cross-section and mounted independently of the cover, is preferred. However, a shelf consisting of a section of rolled angle, properly mounted on the inside of the cover plate, may be used, provided the direction of rotation is such that the charge will be caught on the outside face of the angle.

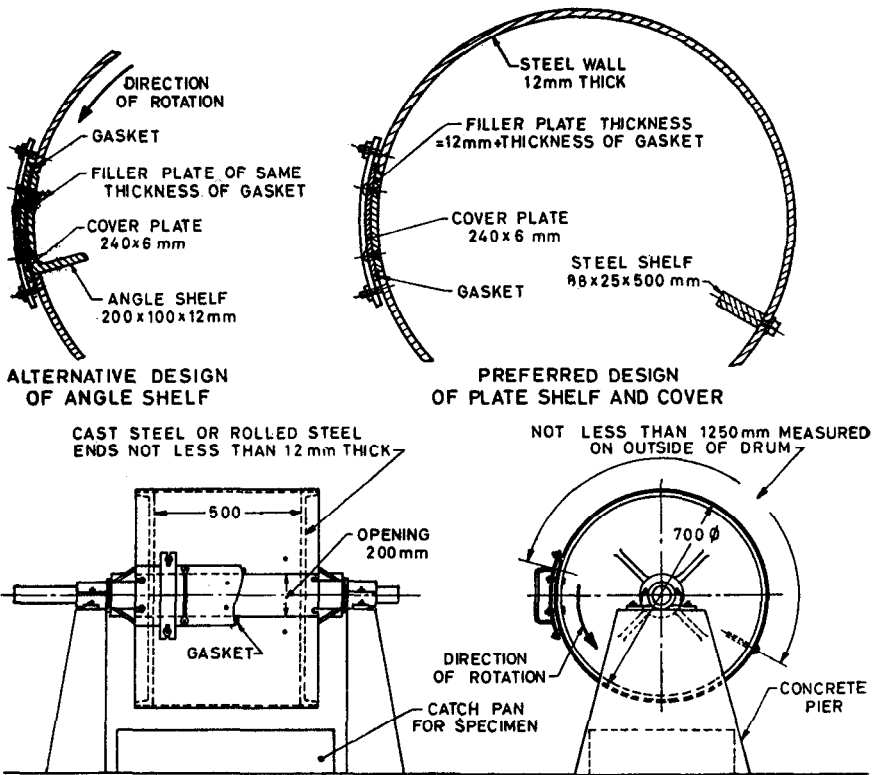

NOTE 1 — Shaft bearing will be mounted on concrete piers or other rigid supports.

NOTE 2 — Suggested horse power for motor is not less than one.

All dimensions in millimetres.

FIG. 3 LOS ANGELES ABRASION TESTING MACHINE

b) *Sieves* — The 1.70-mm IS Sieve.

**5.3.2 Abrasive Charge** — The abrasive charge shall consist of cast iron spheres or steel spheres approximately 48 mm in diameter and each weighing between 390 and 445 g.

5.3.2.1 The abrasive charge, depending upon the grading of the test sample as described in 5.3.3 shall be as follows:

Grading	Number of Spheres	Weight of Charge g
A	12	5 000 ± 25
B	11	4 584 ± 25
C	8	3 330 ± 20
D	6	2 500 ± 15
E	12	5 000 ± 25
F	12	5 000 ± 25
G	12	5 000 ± 25

5.3.3 *Test Sample* — The test sample shall consist of clean aggregate which has been dried in an oven at 105 to 110°C to substantially constant weight and shall conform to one of the gradings shown in Table II. The grading or gradings used shall be those most nearly representing the aggregate furnished for the work.

NOTE — It is recognized that different specification limits may be required for gradings E, F and G than for A, B, C and D. It is urged that investigations be conducted to determine the relationship, if any, which exists between results for these coarse gradings using the 10 000 g samples and the finer ones using the 5 000 g samples.

TABLE II GRADINGS OF TEST SAMPLES

(Clause 5.3.3)

SIEVE SIZE (SQUARE HOLE)		WEIGHT IN g OF TEST SAMPLE FOR GRADE						
Passing	Retained on	A	B	C	D	E	F	G
mm	mm							
80	63	—	—	—	—	2 500*	—	—
63	50	—	—	—	—	2 500*	—	—
50	40	—	—	—	—	5 000*	5 000*	—
40	25	1 250	—	—	—	—	5 000*	5 000*
25	20	1 250	—	—	—	—	—	5 000*
20	12.5	1 250	2 500	—	—	—	—	—
12.5	10	1 250	2 500	—	—	—	—	—
10	6.3	—	—	2 500	—	—	—	—
6.3	4.75	—	—	2 500	—	—	—	—
4.75	2.36	—	—	—	5 000	—	—	—

\*Tolerance of ±2 percent permitted.

### 5.3.4 Procedure

**5.3.4.1** The test sample and the abrasive charge shall be placed in the Los Angeles abrasion testing machine and the machine rotated at a speed of 20 to 33 rev/min. For gradings A, B, C and D, the machine shall be rotated for 500 revolutions; for gradings E, F and G, it shall be rotated for 1 000 revolutions. The machine shall be so driven and so counter-balanced as to maintain a substantially uniform peripheral speed. If an angle is used as the shelf, the machine shall be rotated in such a direction that the charge is caught on the outside surface of the angle. At the completion of the test, the material shall be discharged from the machine and a preliminary separation of the sample made on a sieve coarser than the 1.70-mm IS Sieve. The finer portion shall then be sieved on a 1.70-mm IS Sieve in the manner described in 2.3 of Part I of this standard.

**5.3.4.2** The material coarser than the 1.70-mm IS Sieve shall be washed dried in an oven at 105 to 110°C to a substantially constant weight, and accurately weighed to the nearest gram.

NOTE — Attention is called to the fact that valuable information concerning the uniformity of the sample under test may be obtained by determining the loss after 100 revolutions. When this determination is made, care should be taken to avoid loss of any part of the sample; the entire sample, including the dust of abrasion, shall be returned to the testing machine for the completion of the test.

**5.3.5 Reporting of Results** — The difference between the original weight and the final weight of the test sample shall be expressed as a percentage of the original weight of the test sample. This value shall be reported as the percentage of wear.

## 6. DETERMINATION OF THE POLISHED-STONE VALUE

**6.1 General** — The object of this test is to determine the polished-stone value which gives a relative measure of the extent to which different types of roadstone in the wearing surface will polish under traffic. The results of this test are used for comparative purposes only; limits cannot, at present, be specified for the polished-stone value in any particular set of circumstances. Where the wearing surface of a road consists largely of stone, the state of polish of the stone will be the dominant factor but other factors also affect the resistance of the surface to skidding.

The test is in two parts:

- a) Samples of stone are subjected to an accelerated polishing action in a special machine.
- b) The state of polish reached by each sample is measured by means of a suitable friction test and is expressed as the 'polished-stone value'.

**6.2 Apparatus** — The apparatus shall consist of the following:

- a) An accelerated polishing machine (*see* Fig. 4) which shall be rigidly

mounted on a firm, level and non-resilient base of stone or concrete and shall include:

- 1) A road wheel having a flat periphery, and of such a size and shape as to permit fourteen of the specimens to be clamped on the periphery so as to form a continuous surface of stone particles 45 mm wide and 405 mm in diameter.
  - 2) Means for rotating the road wheel about its own axis at a speed of 320 to 325 rev/min.
  - 3) Means for bringing the surface of a rubber-tyred wheel of 20 cm diameter and 5 cm breadth to bear on the stone surface of the road wheel with a total load of 40 kg. The tyre shall be an industrial 8×2 pneumatic 4-ply rating smooth hand-truck tyre with a hardness of  $55 \pm 5^*$  and shall be inflated to a pressure of  $3.15 \pm 0.15$  kg/cm<sup>2</sup>. It shall be free to rotate on its own axis, which shall be parallel with the axis of the road wheel; the plane of rotation of the tyre shall be accurately in line with that of the road wheel. Before a new tyre is used on an actual test, it shall be given a preliminary run of 3 hours with sand and 3 hours with emery flour, as in an actual test, but using spare specimens. The tyre shall be discarded after 30 test runs have been made with it, or sooner if it shows signs of irregular wear.
  - 4) Means to feed the sand specified in 6.3 and water at a uniform rate and in such a way that the sand and water are continuously and uniformly spread over the surfaces of the tyre and the specimens where they are in contact. This requires about 12 g/min of sand and 20 g/min of water.
  - 5) Means to feed the emery powder specified in 6.3 and water at a uniform rate and in such a way that the emery powder and water are continuously and uniformly spread over the surface of the tyre and the specimens where they are in contact. This requires about 2 g/min of emery powder and 5 g/min of water.
- b) A friction tester complying with the requirements set out in 6.6 and 6.7.
- c) The IS Sieves shall be of the following sizes:
- 10 mm, 8.0 mm (both perforated plate), 425 microns, 300 microns, 212 microns and 150 microns (fine mesh).

---

\*Appendix C of IS : 809-1957 Specification for Rubber Flooring Materials for General Purposes ( Since revised ) gives the method of determining the hardness.

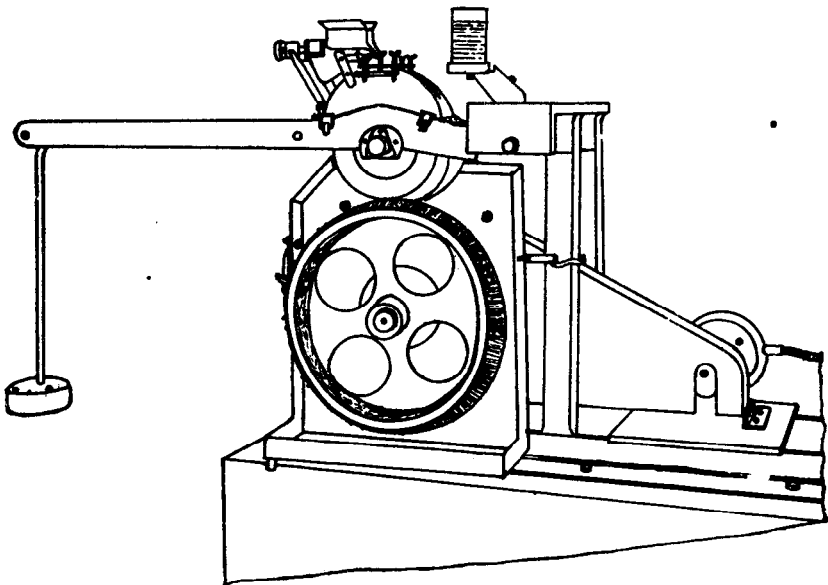
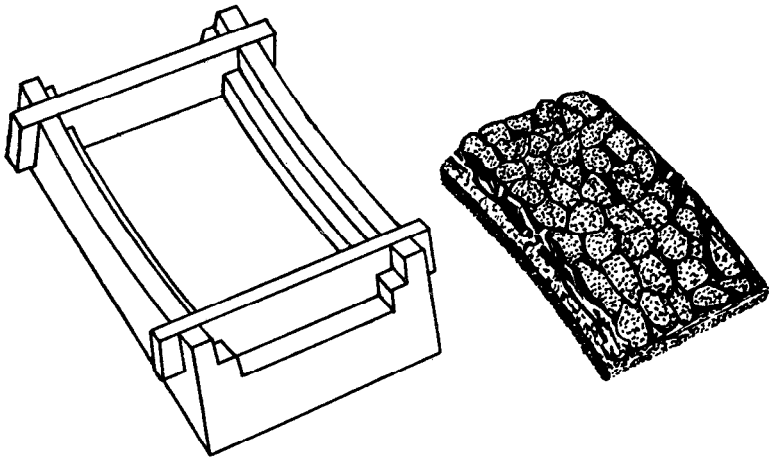

FIG. 4 SPECIMEN AND APPARATUS FOR ACCELERATED POLISHING

**6.3 Materials** — A supply of clean, hard siliceous sand, graded within the following limits; about 2.5 kg will be required for each test run:

<i>Passing IS Sieve</i>	<i>Percentage by Weight</i>
425-micron	100
300-micron	85-100
212-micron	20-50
150-micron	0-5

A supply of air-floated emery powder, 100 percent finer than 0.06 mm and not less than 70 percent finer than 0.002 mm; about 350 g will be required for each test run.

**6.4 Preparation of Specimens** — At least 3 kg of 10-mm particles shall be available for each sample to be tested. The particles actually used in the preparation of the test specimens shall all pass the 10-mm IS Sieve and be retained on the 8.0-mm IS Sieve and shall be neither flaky nor elongated. These shall be clean and free from dust.

**6.4.1** When it is desired to test materials larger than 10 mm which may have characteristics differing from particles of the test size, the particles for the specimen should be obtained by crushing the larger particles.

**6.4.2** Each specimen shall consist of a single layer of 40 to 50 of the particles spaced as closely as possible and covering an area of  $90.5 \times 44.5$  mm, set in a sand-cement mortar\* with their exposed surfaces proud of the mortar. The surface of the specimen shall be flat across the shorter dimension but shall be curved in the arc of a circle of 400 mm diameter along the longer dimension. The individual particles shall be mounted in such a way that the surfaces exposed to wear are as nearly flat as possible, and in any case present no sharp edges to the polishing tyre. The specimens shall be not less than 12.5 mm thick, and shall be of such a shape as to permit their being clamped round the flat periphery of the road wheel of the accelerated polishing machine so as to form a continuous outer surface of particles with an outer diameter of 405 mm. At least two specimens shall be made from each material to be tested.

**6.5 Accelerated Polishing of Specimens** — The specimens shall be rigidly clamped round the periphery of the road wheel of the accelerated polishing machine; the wheel will accommodate 14 specimens, and it has been found useful when mounting the specimens on the wheel to insert strips of polythene† about 0.25 mm thick between and beneath them. The pneumatic-tyred wheel shall be brought to bear on the surface of the

\*The mortar shall consist of a mixture of equal portions by weight of the sand specified in 6.3 and high-alumina cement. It is desirable to reinforce each specimen with 3 pieces of 1.2 mm iron wire laid along the longer dimension.

†It should be noted that the name 'polythene' is equivalent to the name 'polyethylene'.

specimens with a total load of 40 kg and the road wheel started up and brought to a speed of 320 to 325 rev/min. Water and the sand specified in 6.3 shall be fed continuously at the rates specified in 6.2 (a) on the road wheel while it rotates at 320 to 325 rev/min for a period of 3 hours  $\pm 5$  min.

**6.5.1** The machine and specimens shall then be thoroughly cleaned by washing so that all traces of sand are removed and the machine operated for a further three hours as described in 6.5, except that in place of the sand and water the air-floated emery powder specified in 6.3 and water shall be fed continuously at the rates specified in 6.2 (a). After 3 hours  $\pm 5$  min running with the emery powder, the machine shall be stopped and the machine and specimens cleaned. The specimens after polishing are extremely sensitive to handling, and fingering of the polished surfaces shall be avoided. The specimens shall then be tested on the friction tester as described in 6.6.

**6.6 Friction Tester** — The friction test shall be made with a tester (*see* Fig. 5) constructed to drawings supplied by the Road Research Laboratory, UK. The tester shall provide:

- a) a spring-loaded rubber slider of the weight, size and shape specified below, mounted on the end of a pendulum arm so that the sliding edge is 50 cm from the axis of suspension.
- b) means for setting the column of the instrument vertical.
- c) means for rigidly locating one of the curved specimens from the accelerated polishing machine with its longer dimension in the track of the pendulum, centrally with respect to the rubber slider and to the axis of suspension of the pendulum.
- d) means for raising and lowering the axis of suspension of the pendulum so that the slider can (1) swing clear of the surface of the specimen or (2) be set to slide over a fixed length of surface of  $75 \pm 1.5$  mm.
- e) means for holding and releasing the pendulum arm so that it falls freely from a horizontal position.
- f) a pointer balanced about the axis of suspension indicating the position of the pendulum arm throughout its forward swing, and moving over a circular scale drawn up as specified in 6.6.1 to 6.6.3. The weight of the pointer shall be not more than 85 g and the friction in the pointer mechanism shall be adjustable so that, with the pendulum arm swinging freely from a horizontal position, the outward tip of a 30-cm long pointer may be brought to rest on the forward swing of the arm at a point 10 mm below the horizontal.

**6.6.1** The weight of the swinging arm including the slider shall be  $1.500 \pm 0.025$  kg, the centre of gravity lying on the axis of the arm at a distance of  $405 \pm 5$  mm from the centre of suspension.



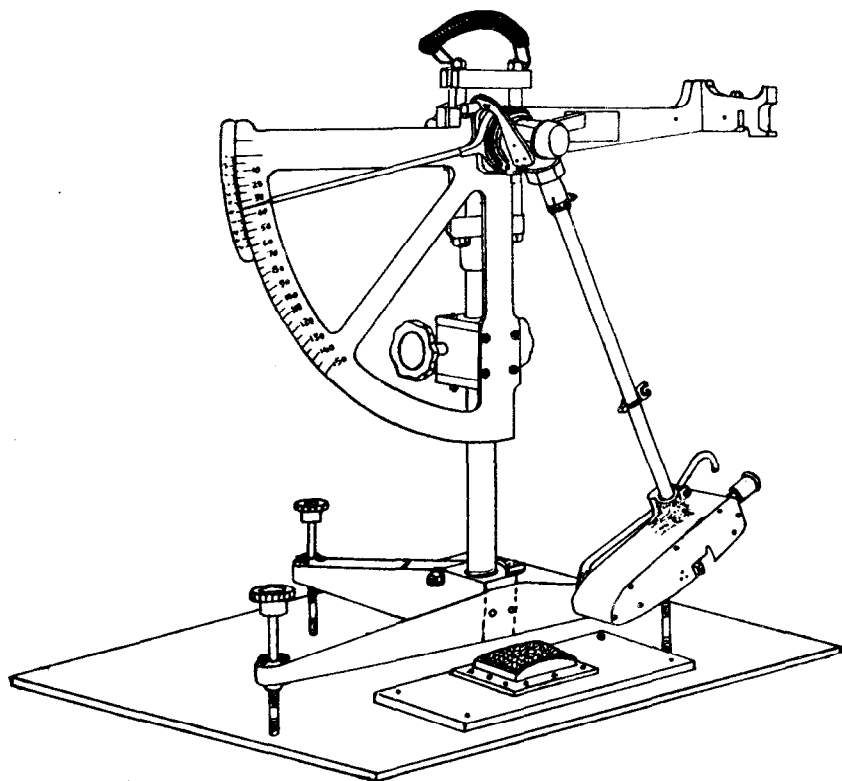

FIG. 5 APPARATUS USED TO MEASURE THE COEFFICIENT OF FRICTION OF THE SPECIMEN

**6.6.2** The slider shall consist of a rubber pad 32 mm wide and 6.5 mm thick held on a rigid base with a total weight of  $25 \pm 2$  g which is mounted on an axis set at an angle of 20 degrees with the horizontal when the pendulum is at the lowest point of its swing, so that (a) only the rear edge of the slider contacts the test surface, and (b) the slider can turn about its axis without obstruction to follow unevenness of the surface perpendicular to the plane of the pendulum swing. The slider shall be spring loaded against the test surface and the load on the slider shall be  $2.25 \pm 0.05$  kg in its mean position; the change in load on the slider shall be not greater than 190 g/cm deflection of the slider.

**6.6.3** The slider shall be made from rubber tested and specially selected for the purpose. Before use, each working end of a new slider shall be

roughened by swinging it at least 10 times over a dry, unpolished specimen, which shall not be one of the specimens to be tested. Each slider shall be used for not more than 500 swings with each of the two usable ends, and shall, in any case, be discarded not more than one year after the date it is supplied.

NOTE — Recent research has thrown new light on the properties of rubber that govern its frictional resistance. Until the results of this research can be applied on a commercial scale, it is essential that the rubber for use in the slider be carefully tested and selected. When so selected, it should last without any ageing effect for at least a year; full instructions on this and other points relating to the use of the portable tester are issued with each instrument.

**6.6.4** All bearings and working parts of the instruments shall be enclosed as far as possible, and all materials used shall be suitably treated to prevent corrosion under wet conditions.

**6.7 Calibration of the Tester** — The scale of the instrument when used for this test shall give the coefficient of friction, expressed as a percentage, and shall be drawn up by means of the following equation:

$$\mu = \frac{W X \zeta}{PD \rho} \times 100$$

where

$\mu$  = effective coefficient of friction, expressed as a percentage;

$W$  = weight in kg of the swinging arm;

$X$  = distance in cm of the effective centre of gravity of the arm from the centre of oscillation;

$\zeta$  = vertical distance of the edge of the scale below the zero of the scale, which shall be 10 mm below the horizontal when the arm is released to swing freely from the horizontal;

$P$  = normal load in kg on the slider;

$D$  = sliding distance in cm; and

$\rho$  = length in cm of the pointer.

The instrument shall be cross-checked with the Road Research Laboratory standard machine on the following wetted surfaces:

- a) A glass plate.
- b) Five smooth-looking surfaces having a texture depth less than 0.25 mm and covering a range of coefficients of friction, expressed as a percentage, of at least 25 to 75 percent.
- c) Five rough-looking surfaces having a texture depth greater than 0.51 mm and covering a range of coefficients of friction, expressed as a percentage, of at least 35 to 70 percent.

On these tests no pairs of results on any surface shall differ by more than  $\pm 3$  percent and the mean results for the 11 samples shall not differ by more than  $\pm 1.5$  percent.

**6.8 Friction Test Procedure** — The test shall be made at a temperature of  $20 \pm 2^\circ\text{C}$ .

**6.8.1** The tester shall rest upon a firm level surface and the levelling screws shall be adjusted so that the column is vertical. The axis of suspension of the pendulum shall then be raised so that the arm swings freely, and the friction in the pointer mechanism shall be adjusted so that when the pendulum arm and pointer are released from the right-hand horizontal position the pointer comes to rest at the zero position on the scale.

**6.8.2** The specimen shall then be rigidly located with its longer dimension lying in the track of the pendulum, and centrally with respect to the rubber slider and to the axis of suspension of the pendulum. The height of the axis of suspension of the pendulum shall then be adjusted so that in traversing the specimen the rubber slider is in contact with it over the whole width of the slider and over a length of  $75 \pm 1.5$  mm of the specimen under a normal load of  $2.25 \pm 0.05$  kg. The surfaces of the specimen and the rubber slider shall then be wetted with a copious supply of clean water, care being taken not to disturb the slider from its set position. The pendulum and pointer shall then be released from the horizontal position and the reading of the pointer recorded to the nearest whole number.

**6.8.3** The procedure shall then be repeated with a second specimen of the same material.

**6.8.4** If the values obtained from the two specimens differ by more than 3 percent, a further specimen or specimens shall be tested until two values agree within this limit.

NOTE — If the tester has not been used for eight hours previously, five swings shall be made on a spare specimen before an actual test is made.

**6.9 Reporting of Results** — The mean of the two values of the coefficient of friction, expressed as a percentage, shall be reported to the nearest whole number as follows:

Laboratory determined polished-stone value\* . . . . .

## 7. DETERMINATION OF CRUSHING STRENGTH

**7.1 General** — When aggregates are not available, this test may be used to give a direct measure of the stress in  $\text{kg}/\text{cm}^2$  at ultimate failure of a rock under a slowly increasing compressive load.

---

\*This is not, and should not be confused with, the 'Sideway force coefficient' or the 'Skid-resistance value' determined on a road.

**7.2 Apparatus** — The apparatus shall consist of the following:

- a) A compression testing machine of suitable capacity and at least one platen having a spherical seating of not more than 2.5 cm radius.
- b) A well-ventilated oven, thermostatically controlled to maintain a temperature of 100 to 110°C.

**7.3 Test Specimens** — The test specimens shall be cylinders of  $25 \pm 0.5$  mm mean diameter and of  $25 \pm 0.5$  mm mean height. In any one specimen, the diameter shall not vary by more than 0.25 mm and the height by not more than 0.15 mm. The end faces shall be at right angles to the cylindrical axis and shall be lapped plane to an accuracy of 0.025 mm.

**7.3.1** The samples from which the test specimens are prepared shall be taken from freshly quarried material and only from pieces which show no evidence of incipient fracture. When planes of structural weakness are discernible, the sample shall be so selected as to furnish some test specimens with the planes of structural weakness at right angles to the cylindrical axis of the specimen.

**7.3.2** The size of the samples shall be approximately  $8 \times 4 \times 4$  cm if the test specimens are to be prepared by grinding only and  $15 \times 15 \times 10$  cm if the test specimens are to be prepared by drilling, sawing and grinding.

**7.3.3** In the preparation of the test specimens, the rock shall not be subjected to any treatment (such as chipping with a hammer) liable to induce incipient fracture. A copious flow of cold water shall be used throughout all grinding, drilling and sawing operations, to ensure that the aggregate is not damaged by overheating.

**7.3.4** The test specimens shall be dried for four hours in the oven at a temperature of 100 to 110°C and cooled before test.

**7.3.5** If no planes of structural weakness are apparent, three specimens shall be tested. If planes of structural weakness are apparent, four specimens shall be tested, of which two shall have the planes at right angles to the axis of the cylinder.

**7.4 Procedure** — The diameter and height of each specimen shall be measured to an accuracy of 0.025 mm. The specimen shall be placed centrally between the steel platens without packing.

**7.4.1** Each test shall be a direct compression test in which the load is applied to the ends of the cylindrical test specimen at a rate of about 5 tonnes per minute. In making each test, the final load necessary to produce crushing of the specimen shall be observed.

**7.5 Calculations** — The stress shall be calculated in  $\text{kg/cm}^2$  from the cross-sectional area of the specimen.

**7.6 Reporting of Results** — The value of the crushing stress for each individual specimen, and the average crushing stress shall be reported to the nearest 5 kg/cm<sup>2</sup>. Any peculiar condition of a test specimen which might affect the result of the test, such as the presence of seams, fissures, etc, shall be noted in the report.

# BUREAU OF INDIAN STANDARDS

## Headquarters:

Manak Bhavan, 9 Bahadur Shah Zafar Marg, NEW DELHI 110002

Telephones: 323 0131, 323 3375, 323 9402

Fax : 91 11 3234062, 91 11 3239399, 91 11 3239382

Telegrams : Manaksanstha  
(Common to all Offices)

## Central Laboratory:

Plot No. 20/9, Site IV, Sahibabad Industrial Area, SAHIBABAD 201010

Telephone  
8-77 00 32

## Regional Offices:

Central : Manak Bhavan, 9 Bahadur Shah Zafar Marg, NEW DELHI 110002 323 76 17

\*Eastern : 1/14 CIT Scheme VII M, V.I.P. Road, Maniktola, CALCUTTA 700054 337 86 62

Northern : SCO 335-336, Sector 34-A, CHANDIGARH 160022 60 38 43

Southern : C.I.T. Campus, IV Cross Road, CHENNAI 600113 235 23 15

†Western : Manakalaya, E9 Behind Marol Telephone Exchange, Andheri (East),  
MUMBAI 400093 832 92 95

## Branch Offices:

'Pushpak', Nurmohamed Shaikh Marg, Khanpur, AHMEDABAD 380001 550 13 48

‡Peenya Industrial Area, 1st Stage, Bangalore - Tumkur Road,  
BANGALORE 560058 839 49 55

Gangotri Complex, 5th Floor, Bhadbhada Road, T. T. Nagar, BHOPAL 462003 55 40 21

Plot No. 62-63, Unit VI, Ganga Nagar, BHUBANESHWAR 751001 40 36 27

Kalaikathir Buildings, 670 Avinashi Road, COIMBATORE 641037 21 01 41

Plot No. 43, Sector 16 A, Mathura Road, FARIDABAD 121001 8-28 88 01

Savitri Complex, 116 G. T. Road, GHAZIABAD 201001 8-71 19 96

53/5 Ward No. 29, R. G. Barua Road, 5th By-lane, GUWAHATI 781003 54 11 37

5-8-58C, L. N. Gupta Marg, Nampally Station Road, HYDERABAD 500001 20 10 83

E-52, Chitaranjan Marg, C-Scheme, JAIPUR 302001 37 29 25

117/418 B, Sarvodaya Nagar, KANPUR 208005 21 68 76

Seth Bhawan, 2nd Floor, Behind Leela Cinema, Naval Kishore Road,  
LUCKNOW 226001 23 89 23

Patliputra Industrial Estate, PATNA 800013 26 23 05

T. C. No. 14/1421, University P. O. Palayam,  
THIRUVANANTHAPURAM 695034 6 21 17

NIT Building, Second Floor, Gokulpat Market, NAGPUR 440010 52 51 71

Institution of Engineers ( India ) Building, 1332 Shivaji Nagar, PUNE 411005 32 36 35

\*Sales Office is at 5 Chowringhee Approach, P. O. Princep Street,  
CALCUTTA 700072 27 10 85

†Sales Office is at Novelty Chambers, Grant Road, MUMBAI 400007 309 65 28

‡Sales Office is at 'F' Block, Unity Building, Narashimaraja Square,  
BANGALORE 560002 222 39 71

AMENDMENT NO. 2 SEPTEMBER 1981

TO

IS:2386(Part IV)-1963 METHODS OF TEST FOR  
AGGREGATES FOR CONCRETE  
PART IV MECHANICAL PROPERTIES

Alterations

(Page 8, Note 1 under clause 2.6, last sentence) -  
Delete.

(Page 13, clause 5.1) - Substitute the following  
for the existing clause:

'5.1 Object - This test covers the method of determining  
the abrasion value of coarse aggregate by the use of Los  
Angeles machine (see 5.2).'

(Pages 14 to 16, clauses 5.2 to 5.2.7) - Delete  
and renumber the subsequent clauses accordingly.

(BDC 2)

AMENDMENT NO. 3      OCTOBER 1983

TO

**IS : 2386 ( Part IV ) - 1963    METHODS OF  
TEST FOR AGGREGATES FOR CONCRETE**

**PART IV    MECHANICAL PROPERTIES**

**Alterations**

( *Page 5, clause 2.2* ) — Substitute the following for the existing clause:

**‘2.2 Apparatus** — The apparatus for the standard test shall consist of the following:

- a) An open-ended 150 mm cylindrical cell with appropriate base plate and plunger, metal measure and tamping rod conforming to IS : 9376-1979 Specification for apparatus for measuring aggregate crushing value and ten percent fines value;
- b) A balance of capacity 3 kg readable and accurate to one gram;
- c) IS sieve of sizes 12.5 mm, 10 mm and 2.36 mm; and
- d) A compression testing machine capable of applying a load of 40 tonnes in not more than 10 minutes at a uniform rate of loading. The machine may be used with or without a spherical seating.

( *Page 5, Table 1, Note* ) — Substitute the following Note for the existing:

‘**NOTE** — About 6.5 kg of natural aggregates is required to provide two test samples for 15 cm cylinder and about 1 kg for 7.5 cm cylinder. For lightweight aggregates, the quantity will vary depending on the density of the aggregate.’

( *Page 6, Fig. 1* ) — Delete.

( *Page 7, clause 2.3.2* ) — Substitute the following for the existing clause:

**‘2.3.2** The quantity of aggregate shall be such that the depth of material in the cylinder, after tamping as described in 2.3.3, shall be about 10 cm.’

( *Page 8, clause 2.6 Note 1, last sentence* ) — Delete.



( Page 8, clause 2.6 Note 2 ) — Substitute the following Note for the existing:

‘NOTE 2 — *Aggregates smaller than 10 mm* — In general the smaller sizes of aggregates will give a lower aggregate crushing value, but the relationship between the values obtained with different sizes will vary from one aggregates to another. The tests on smaller aggregates may be made either using the standard apparatus described in 2.2 or a smaller apparatus consisting of a 75 mm cylindrical cell with appropriate accessories conforming to IS : 9376-1979 Specification for apparatus for measuring aggregates crushing value and ten percent fines value. In case a smaller apparatus is used, the errors for the smaller sizes of aggregate tested in the smaller apparatus are compensated since the results obtained with the smaller apparatus have been found to be slightly higher than those with the standard apparatus.

The accessories for the smaller apparatus shall be a balance of capacity 500 g, readable and accurate to 0.2 g; IS sieves of appropriate sizes as given in Table 1; and a compression testing machine capable of applying a load of 10 tonnes in not more than 10 min at a uniform rate of loading. Further, in the test using the smaller apparatus, the depth of material in the 75 mm cylinder shall be about 50 mm and the total load applied in 10 min shall be 10 tonnes.’

( Pages 8 and 9, clause 3.2 ) — Substitute the following for the existing clause:

‘3.2 Apparatus — The apparatus shall consist of the following:

- a) A 150 mm cylindrical cell with appropriate plunger and base plate, tamping rod and metal measure conforming to IS : 9376-1979 Specification for apparatus for measuring aggregate crushing value and ten percent fines value;
- b) A balance of capacity 3 kg, readable and accurate to one gram;
- c) IS sieves of sizes 12.5 mm, 10 mm and 2.36 mm;
- d) A compression testing machine capable of applying a load of 50 tonnes in not more than 10 minutes at a uniform rate of loading. The load may vary from 0.5 to 50 tonnes; and
- e) A means of measuring the reduction in the distance between the platens of the testing machine to the nearest one mm during the test ( for example, a dial gauge ).

( Page 9, clause 3.3.2 ) — Substitute the following for the existing clause:

‘3.3.2 The quantity of aggregate shall be such that the depth of material in the cylinder, after tamping as described in 3.3.2.1, shall be about 10 cm.’

[ Page 19, clause 5.3.4.1 ( see also Amendment No. 2 ), third line ] — Substitute ‘ 30 to 33 rev/min ’ for ‘ 20 to 33 rev/min ’.

[ Page 19, clause 5.3.5 ( see also Amendment No. 2 ) ] — Substitute the following for the existing clause:

‘5.3.5 Reporting of Results — The difference between the original weight and the final weight of the test sample shall be expressed as a percentage

of the original weight of the test sample. The mean of two results shall be reported as the percentage of wear. ’

( *Pages 26, 27 and 28, clauses 7 to 7.6* ) — Delete.

### **Addendum**

( *Page 7, clause 2.3.3* ) — Add the following at the end of the clause:

‘( *see Note given in Table 1* )’

( BDC 2 )